

February 08, 2024

LED LIGHTING AND CONTROLS GUIDANCE FOR FEDERAL BUILDINGS

Green Proving Ground | Pacific Northwest National Laboratory



»» Agenda

Logistics

Andrea Silvestri, GSA Green Proving Ground

Introduction (5 minutes)

Kevin Powell, Director GSA Center for Emerging Building Technologies

LED Lighting and Controls Guidance (35 minutes)

Michael Myer, Principal Investigator, Pacific Northwest National Laboratory

Q&A (20 minutes)

»» How to Ask Questions

Click the Q&A button to ask questions.

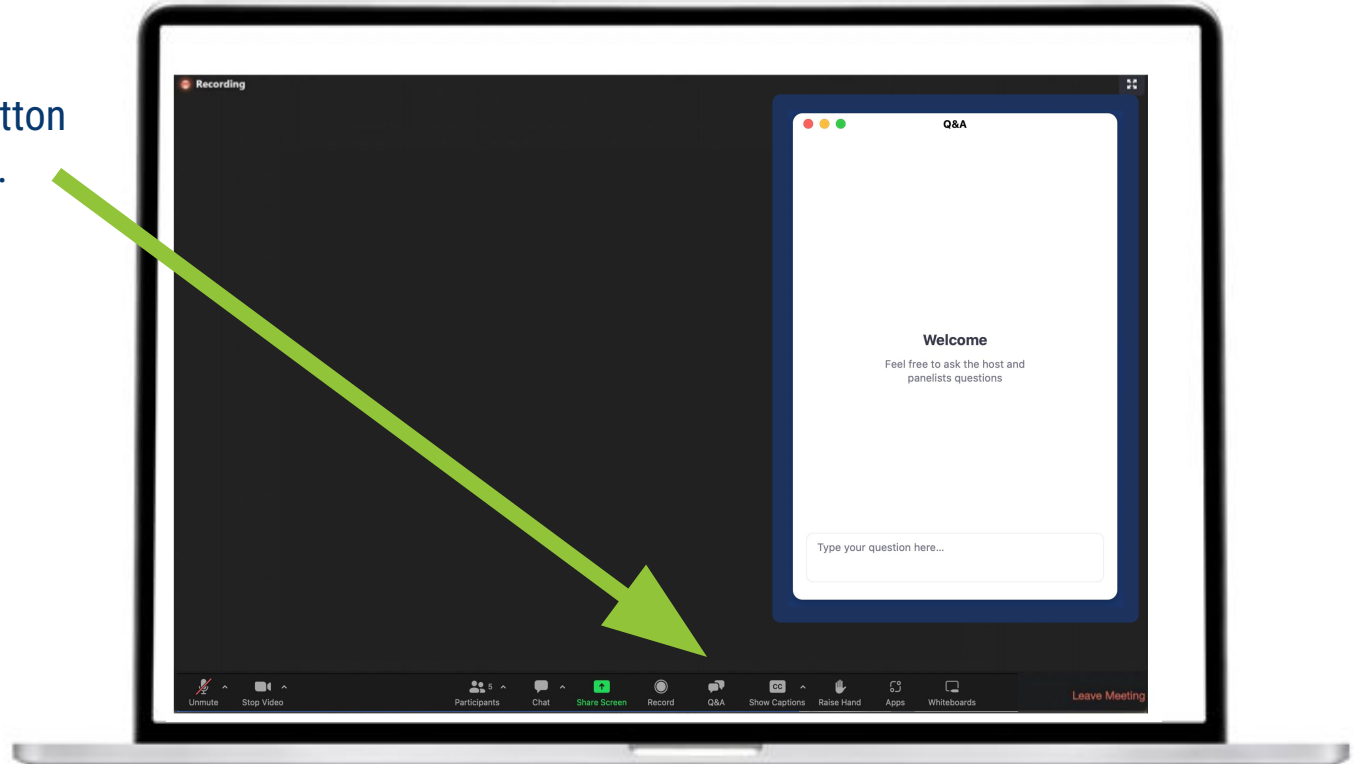

» Webinar Recording and Slides

@ gsa.gov/

The webinar is being recorded.

The recording and slides will be shared by email and posted to gsa.gov.

The screenshot shows the GSA website's 'GPG Webinars' page. The header includes the GSA logo and 'U.S. General Services Administration'. A navigation menu lists categories like 'Buy through us', 'Sell to government', 'Real estate', 'Policy and regulations', 'Small business', 'Travel', 'Technology', and 'About us'. The breadcrumb trail is 'Home > Climate Action and Sustainability > Center for Emerging Building Technologies > GPG Webinars'. The sidebar on the left contains links: 'Overview', 'About Green Proving Ground', 'Completed Assessments', 'Ongoing Assessments', 'Pilot Your Emerging Tech at GSA: FY24 RFI', 'About Pilot to Portfolio', 'GPG Webinars' (highlighted), 'About Applied Innovation Learning Lab', and 'GSA Technology Deployment Maps'. The main content area features a 'GPG Webinars' section with a description: 'GPG webinars present results from real-world evaluations and feedback from facility managers at test-bed locations. Following each presentation, researchers and other GSA subject-matter experts answer questions.' Below this is a note about GSA attendees being eligible for one Continuous Learning Point (CLP) and members of the American Institute of Architects (AIA) being eligible for one health, safety, and welfare (HSW) credit. The 'Upcoming webinars' section lists 'LED Lighting and Controls Guidance for Federal Buildings' on Thursday, February 8, 2024 at 12:00 p.m. ET, with a 'Register' button. The 'On-demand technology webinars' section contains a table with two rows of webinar recordings.

Category	Topic	Date	Video
Building Envelope	Automated Building Envelope Sealing	2023-12	
Building Envelope	Electrochromic Windows for Office Space	2018-04	

December 2023

LED LIGHTING AND CONTROLS GUIDANCE

Published on [gsa.gov](https://www.gsa.gov)

LED LIGHTING AND CONTROLS

Guidance for Federal agencies to select the most cost-effective and energy-efficient lighting systems available

Use the guide as a roadmap and reference to select the best lighting system for your facility

The guide includes flowcharts that illustrate LED and control options with the best return on investment. It provides deployment guidance and implementation considerations and offers best practices and lessons learned from past GPG evaluations.

Decision Flowchart for Retrofitting Linear LED Lighting

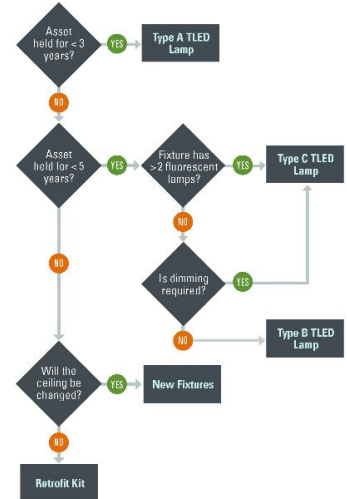

Decision Flowchart for Lighting Controls

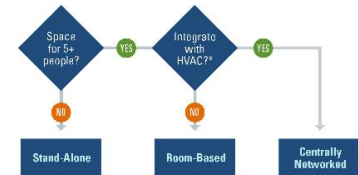

»» Welcome



Kevin Powell

Director, Center for Emerging Building Technologies

kevin.powell@gsa.gov

» Introduction to the Guide

In recognition that lighting accounts for 10%–25% of building electricity use, Congress recently passed the [BRIGHT Act](#) (Bulb Replacement Improving Government with High-Efficiency Technology). It requires federal buildings to use the most life-cycle cost-effective and energy-efficient lighting technology available today, and GSA to issue guidance on how best to do so.

The guide incorporates lessons learned and best practices from 7 GPG evaluations.



» Subject Matter Expert



Michael Myer

Researcher, Pacific Northwest National Laboratory

michael.myer@pnnl.gov

» Interior LED Retrofit Options



TLED-A (uses existing fluorescent ballast)

- Pros: least expensive 1st cost
- Cons: most ballasts will fail shortly; 7 states have banned fluorescent tubes

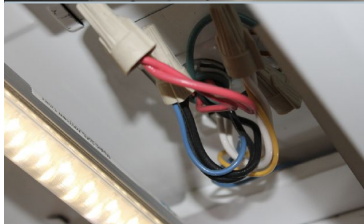

TLED-B (bypasses ballast with direct wiring)

- Pros: can be delivered “sight unseen”
- Cons: relies on optics of existing troffer; glare and distribution



TLED-C (new LED driver)

- Pros: 1 driver can operate multiple lamps; controls can be added
- Cons: relies on existing wiring; glare and distribution

» Interior LED Retrofit Options



Troffer Retrofit Kit

- Pros: can include integrated controls
- Cons: challenging to match different sizes; requires communication



New Fixture

- Pros: aesthetics, longer-lived than retrofit kits
- Cons: more expensive than retrofit kit, requires ceiling modification

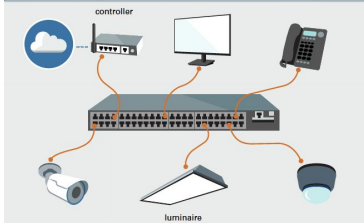

Power-over-Ethernet (POE) Lighting

- Pros: eliminates AC/DC conversion, material and labor savings
- Cons: more planning and design, cybersecurity

» Consider the Following When Selecting an LED System

- Circadian Lighting
- Color Rendering
- Color Temperature
- Communication Protocols
- Controls Interfaces
- Controls-Ready Fixtures
- Dimming
- Drivers
- Distribution
- Efficacy
- Flicker



» Color Temperature

- CCT is an imprecise metric. As a result, two products can have the same CCT value and may not appear the same.
- Some light fixtures have multiple CCT values. Electricians can select from 2–3 CCT options using a dip switch.
- Most occupants prefer warmer color temperatures; 3000 K and 3500 K are the most common preferences.
- Some applications or tasks such as fine detail work may require CCT values greater than 4100 K.

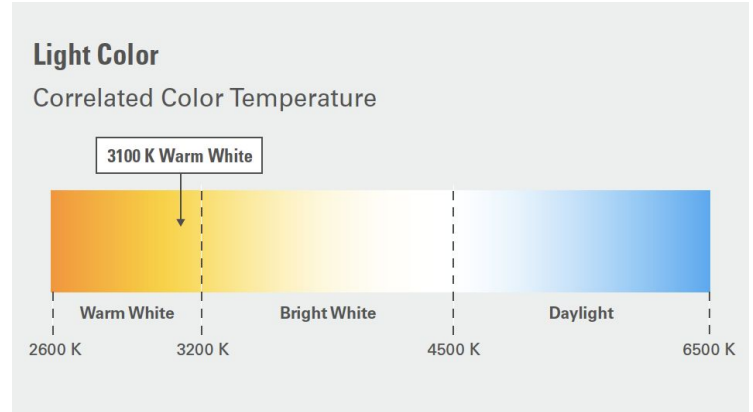

Example of low, warm, and high CCT.

»» Color Rendering / Fidelity

- For good color, high color rendering or ANSI/IES TM-30 values should be considered. This is different than CCT.
- GSA's PBS-100 requires interior lighting to have a CRI of 80 or greater an exterior lighting to have a CRI of 70 or greater.
- Industry has moved to ANSI/IES TM-30
- GSA's also allows ANSI/IES TM-30 color fidelity requirements of Rf of 85 or greater.



CRI



TM-30

» Flicker





- Flicker is a function of the frequency of the electrical signal and the duty cycle.
- Some LED drivers use low frequencies that can cause flicker.
- To reduce the potential for flicker, LED driver should be high frequency and not have rectangular or complex waveforms. These drivers currently tend to be more expensive and larger.

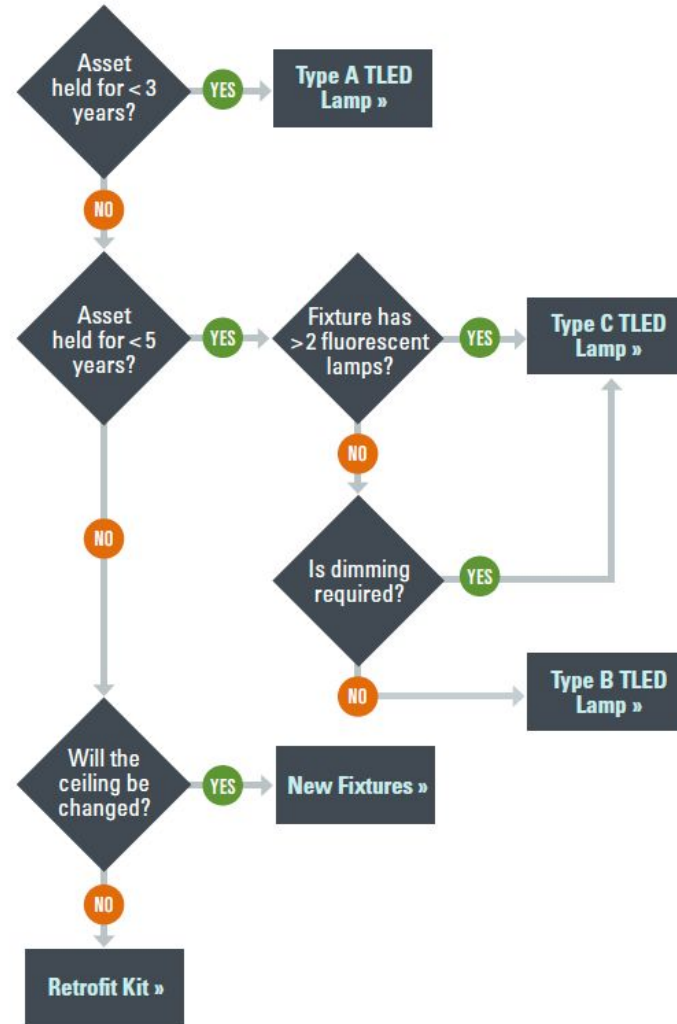

»» Decision Flowchart for Linear LED



» Energy Savings Controls

Control Strategy	Lighting Savings					Integrated System Savings	
	Scheduling	Occupancy Sensing	Dimming	Daylight-Responsive Control	Task Tuning	Demand Response	HVAC Integration
							
Typical Energy Savings¹	40% lighting if lights are on 24/7	24% lighting ²	20% (will depend on your preference)	28% lighting ³	20%+ lighting ⁴	20% kW reduction (not energy) ⁵	30% HVAC ⁶
Code Compliance	GSA PBS-P100 ASHRAE/IES 90.1	GSA PBS-P100 ASHRAE/IES 90.1	GSA PBS-P100 ASHRAE/IES 90.1	GSA PBS-P100 ASHRAE/IES 90.1	—	Supports GSA's GEB initiative	Unoccupied setpoints will be required in ASHRAE/IES 90.1 2022
Minimum System Requirements	Scheduler with astronomic and time- and day-based functions	Occupancy sensors	LED naturally dims	Daylight sensors	Digital communication protocol Centrally networked system	Digital communication protocol Centrally networked system	Digital communication protocol Centrally networked system

» Controls Offer Diminishing Returns

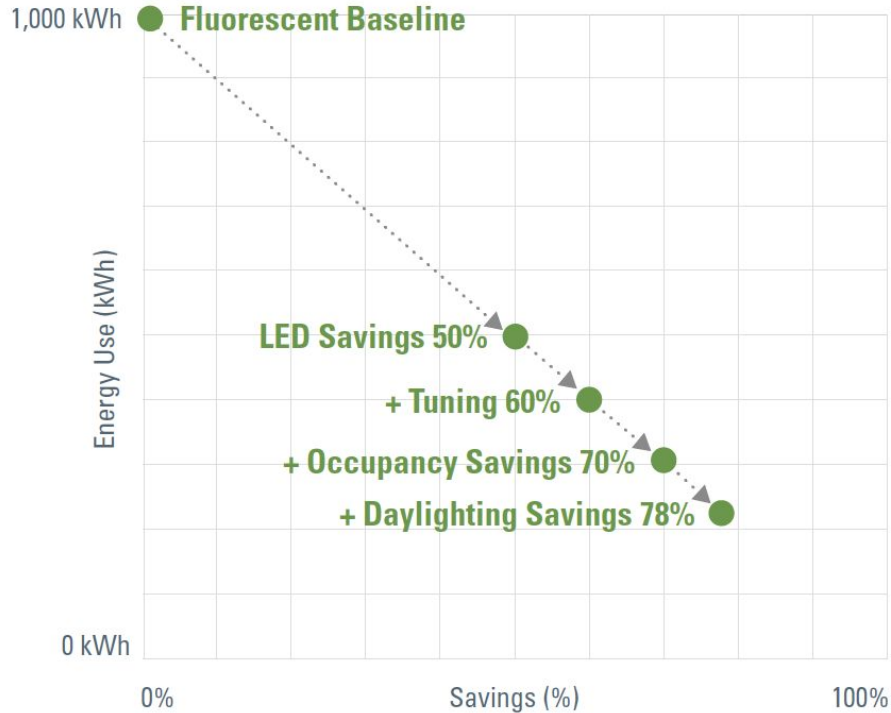

Controls offer significant savings but it can be challenging to realize a positive ROI because LED lighting is so efficient.

» Steps for Designing a Lighting Control System

1

Review Energy Code Requirements

Control requirements will vary by space type.

2

Assess Need for Enhanced Capabilities

Determine if additional energy savings or lighting performance capabilities are needed.

3

Design Lighting Zones

Determine the final size of zones, number of luminaires, and layout of each zone.

4

Select a System Architecture

System architecture can be stand-alone, room-based with a controller, or centrally networked.

5

Determine Sensor and Controller Locations

Sensors can be located in each luminaire for luminaire-level lighting control or in the space for zone-based control.

6

Configure Control Wiring

Control systems can be wired, wireless, or a combination of both.

7

Identify Communication Protocols

The lighting communication protocol refers to how the LED array communicates with the LED driver within the luminaire.

8

Plan for Retro- and Re-Commissioning

Lighting systems need to be updated regularly to accommodate system updates and building changes.

» 1. Review Energy Code

- Determine system controls that are code compliant, based on space type.
- Current ASHRAE/IES Std. 90.1 include:
 - Occupancy sensing for restrooms and offices larger than 300 ft²
 - Small private offices require both a local control and an automatic off.

ASHRAE/IES Minimum Control Requirements by Space Type

Common Space Types ^a	LPD, W/ft ²	RCR	Local Control	Manual ON	Partial Auto ON	Multilevel Lighting Control	Daylight Response Sidelight
			9.4.1.1(a)	9.4.1.1(b)	9.4.1.1(c)	9.4.1.1(d)	9.4.1.1(e) ^b
Office							
Office ≤150 ft ²	0.73	8	REQ	ADD1	ADD1	REQ	
Office >150 and ≤300 ft ²	0.66	8	REQ	ADD1	ADD1	REQ	
Offices >300 ft ²	0.56	4	REQ	ADD1	ADD1	REQ	REQ

» 2. Assess Need for Enhanced Capabilities

- **HVAC Setback.** Because more occupancy sensors may be necessary for HVAC integration, a luminaire-level lighting control (LLLC) design may be ideal for this capability.
- **Demand Response.** Lighting can either turn off or dim in response to DR events. Dimming is preferred because it allows the space to remain functional and is often unnoticed by occupants. Requires a centrally networked system.
- **Asset and Occupant Tracking.** Requires LLLC controls that are centrally networked.
- **Energy Reporting and System Diagnostics.** New LED drivers (i.e., power supply for the light fixture) are digital, contain energy measurement chips, and can allow for reporting about operations. Requires a lighting control system that uses digital drivers and is centrally networked.

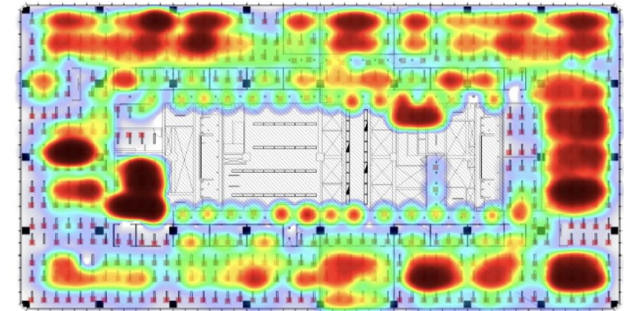
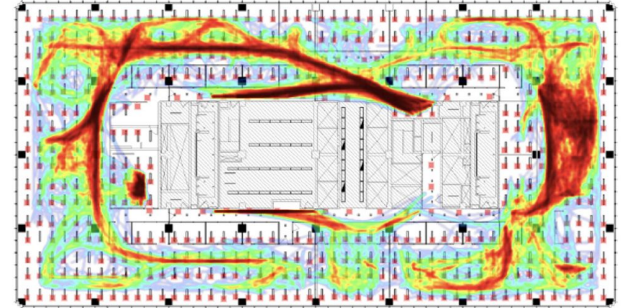

Embedded Sensors in an LLLC System Capture Occupancy Flow and Presence (Enlighted)

» HVAC Integration

- Energy codes are adopting “occupied-standby” requirements: spaces required to have lighting occupancy sensors, the HVAC system must set back temperature by at least 1° and modulate fans when unoccupied for > 5 minutes
- HVAC integration is a good choice for networked lighting systems with LLLC
- Using the same sensors to control both lighting and HVAC improves cost recovery
- DOE case studies have demonstrated HVAC savings > 20%
- Engage a system integrator or someone knowledgeable about both HVAC and lighting

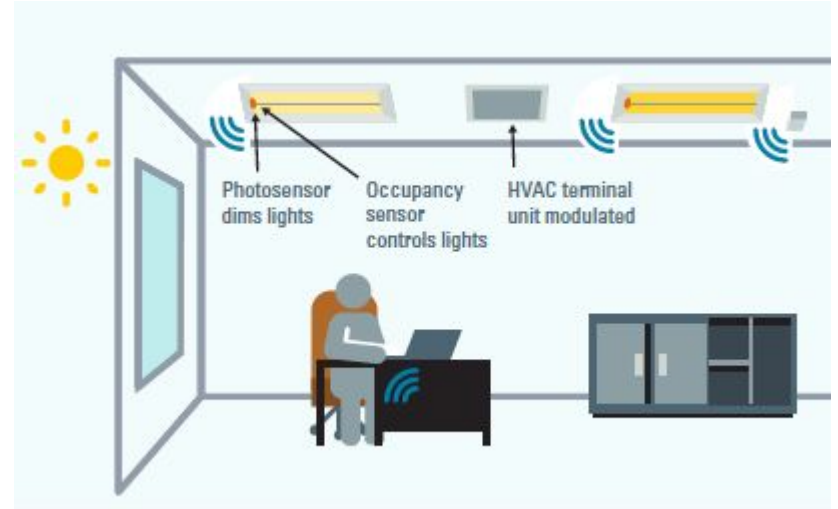

Integrating Lighting Sensors with HVAC Can Improve ROI by 30%

» Demand Response

- Target locations with demand charges that exceed \$5/kW.
- Best suited to open offices, courtrooms, and atriums.
- Lighting can be dimmed in a matter of minutes.
- 20% reduction is imperceptible to the eye.
- Because LEDs are so efficient, lighting loads are smaller, so available power to shed is lower than in other building systems.
- Daylight harvesting may minimize the impact of load shedding.
- Demand response / load shed will require a centrally networked system with greater IT security clearance.

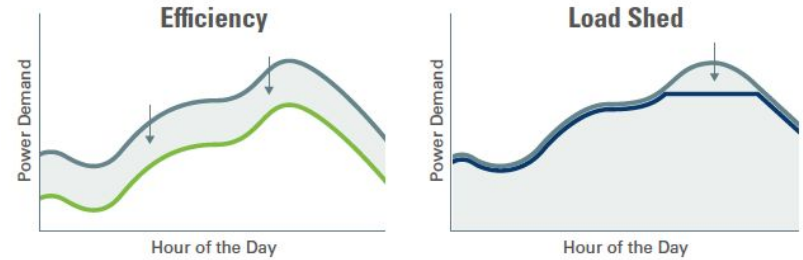

LED Lighting is a good grid-interactive efficient building (GEB) Strategy

»» 3. Design Lighting Zones

- Determine minimum zone sizes per code requirements
- Group zones by fixture type, application and location
- Limit the total number of zones
- Physical wiring of zones requires an electrician
- The dimming method must be the same for all lights within the zone
- With LLLC, each luminaire can be its own zone for certain capabilities (e.g., daylight responsive controls) and part of larger zones for others (e.g., occupancy sensing, time scheduling)

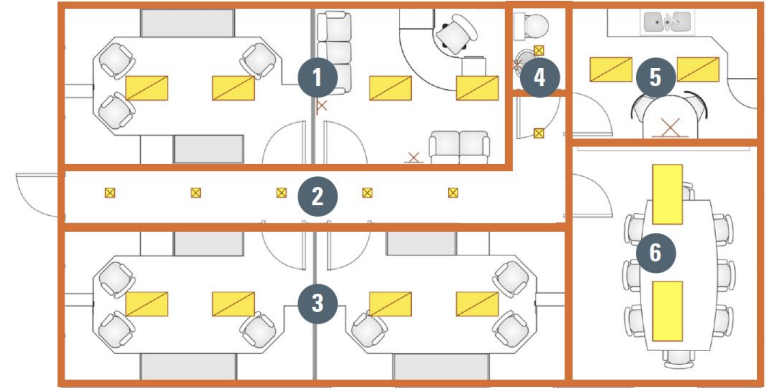

Design Lighting Zones by Fixture Type, Application, & Location

» 4. System Architecture

Stand-Alone controls have no interactions or communication with each other.

Room-Based controller communicates with luminaires in a room. Does not integrate with the grid or HVAC.

Centrally Networked includes a centralized control point where users can modify the system and integrate with other systems.

Feature	Stand-Alone	Room-Based	Centrally Networked
# of Luminaires	1 luminaire to a single room	3 or 4 zones in a room; limited by the size of the circuit powering it	Multiple luminaires, multiple rooms, even multiple buildings
# of Control Strategies	1 or 2	1-3	1-5 or more
Installed Cost	< \$1/ft ²	< \$1/ft ²	\$3/ft ²
Demand Reduction	No	No	Yes
BAS and/or HVAC Integration	No	No	Yes
Allows for Expansion	In limited applications	Yes	Yes
Cybersecurity Risk	None to low	None to low	Medium to high

»» 5. Determine Sensor and Controller Locations

- LLLC systems include sensors embedded in the luminaire and will provide more granular design than a zone-based control. Better choice if you're seeking control features beyond those that meet minimum energy codes.
- In a zone-based lighting system, a sensor is located amongst a group of luminaires. The sensor will need to be wired to control the luminaires or be wireless; both can add additional labor costs.



Federal Agency IT Security

- All lighting hardware goes through a remediation process, whether it's networked or not.
- Networked lighting systems go through an additional IT security process to determine how the system gets connected to the building.
- If there is a cloud-based component, it will need Federal Risk and Authorization Management Program (FedRAMP).

» 5. Sensor and Controller Locations



Luminaire-Level Lighting Control (LLLC)

- Consider for spaces that require more than 5 sensors and have daylight or variable occupancy
- Each sensor has to be commissioned, about 30 minutes per luminaire
- Eliminates the need for separate sensor and power installation

Zone-Based Control

- Consider for private offices, spaces that need fewer than 5 sensors, low-occupancy/high transitory spaces
- Zone-based control requires more labor to install than an LLLC system

»» 6. Configure Control Wiring

- Systems can be wired, wireless, or a combination.
- Wireless indicates how data is communicated but does not mean the device is entirely wireless.
- Some wireless equipment is powered by a battery, which typically has a 10-year life. Other wireless equipment requires a physical power source.

Feature	Wired	Wireless
Construction type	Primarily new	New or retrofit
Allowed per PBS-P100	Yes	Yes
Stand-alone controls	Hardwired to sensor	Wireless (non-WiFi) occupancy sensor options exist
Possible limitations	Will need to be rewired as space changes	Signals can be reduced by some building materials
Cost	Labor: More labor time and materials for running wires IT: Shorter cyber scan period Materials: lighting, controls, wires, conduit – \$5/ft ²	Labor: Short labor time, just place nodes and gateways IT: Longer cyber scan period Materials: lighting, controls, beacon, gateway – \$4/ft ²
Integrates with BAS	Possible	Possible

» 7. Identify Communication Protocols

Feature	Analog (0–10V)	Digital (DALI-2)
Data Exchange	<ul style="list-style-type: none">• One-way	<ul style="list-style-type: none">• Two-way
Luminaire Addressability	<ul style="list-style-type: none">• No	<ul style="list-style-type: none">• Yes• Enables advanced features such as reporting run time, energy use, and failures
Zoning Flexibility	<ul style="list-style-type: none">• Determined by wiring	<ul style="list-style-type: none">• Can be reconfigured in software
Dimming Precision	<ul style="list-style-type: none">• Inconsistent dimming output between products. Some 0–10V drivers have a maximum output of 90%.• No standardized luminaire response signal. One luminaire may dim to 60% at 7V and another may dim to 80% at 7V.	<ul style="list-style-type: none">• Consistent logarithmic dimming, matching the eye’s sensitivity• Standardized response signal. Different fixture types respond the same.
Cybersecurity Risk	<ul style="list-style-type: none">• None to low	<ul style="list-style-type: none">• None to low• If a 0–10V lighting system has already passed cyber security clearance, it should be a small add-on to have a digital driver remediated.
Availability	<ul style="list-style-type: none">• Widely available with greater familiarity	<ul style="list-style-type: none">• Most manufacturers have at least two DALI-2 options

» Open Protocol: DALI-1 vs DALI-2

- DALI-1 only applied to control gear and lacked certification, and GSA installations experienced multiple issues with proprietary controls and manufacturers going out of business.
- DALI-2 launched in 2017. Certification ensures compatibility.
- DALI-2 is worldwide standard. North America has been slower to adopt but all major lighting control manufacturers offer DALI control and the DALI Alliance lists over 4,000 [certified DALI-2 products](#).

	DALI-1 2002–2017	DALI-2 2017–
Includes control gear (e.g., LED Drivers)?	X	X
Includes control devices (e.g., input devices, application controllers) and other devices?		X
Test sequences designed to ensure product interoperability?		X
Test results verified by DALI Alliance?		X

» 8. Plan for Retro- and Re-Commissioning

- Lighting systems need to be updated regularly to accommodate firmware and system feature updates and building changes.
- Develop a maintenance schedule
- Plan for firmware and other updates.
- Avoid operating in “island” mode.
- Plan to recommission the building every to 2 to 5 years.

Retro- and Re-Commissioning Steps



»» Decision Flowchart for Lighting Controls

* Heating, ventilation, and air conditioning (HVAC) integration is recommended for buildings over 50k ft²; consider for buildings over 25k ft²

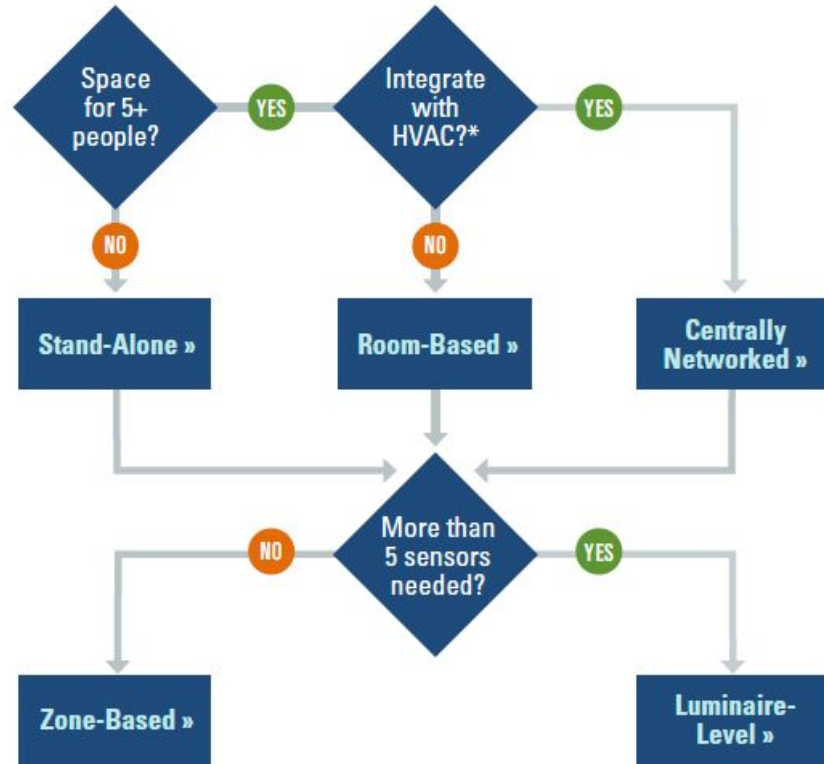

» Life-Cycle Cost Effectiveness

- Capture all cost inputs in LCC analysis
- Integrating with HVAC can be the most cost-effective for larger spaces
- 7 states have banned sales of fluorescent tubes, start planning for lighting upgrades
- ESPC may use the low 1st cost of LED (e.g., Type A TLED) to offset other non-lighting ECMs
 - Will be hard to make LED upgrade pay off in subsequent ESPC
 - Ballasts have \approx 12-year life. If ballasts were not replaced as part of ESPC, expect ballast failures to occur

Retrofit Kits	SYSTEM LIFE (yrs)	ENERGY SAVINGS (%)	ENERGY SAVINGS (/ft ²)	ENERGY SAVINGS (\$ / ft ²)	FIRST COST (\$ / ft ²)	PAYBACK (yrs)	LCC 15-YEAR
Retrofit kit with zone-based control	15	65%	1.87 kWh 6.38 kBtu	\$0.21	\$1.67	8.1	\$170,182

- As building size increases, a retrofit may involve both a combination of mostly retrofit kits and some TLEDs.
- As size increases, retrofit installation becomes more efficient.
- Requires either low voltage wires or wireless communication between the sensor and the luminaires.
- Ideal for low occupancy transitory spaces (e.g., restrooms, corridors, stairs, etc.).
- Spaces with many different fixture types and many custom or outlier fixture types may make finding retrofit kits more difficult.

Retrofit kit with luminaire-level lighting control (LLLC), room-based	15	65%	1.87 kWh 6.38 kBtu	\$0.21	\$2.27	11.0	\$200,882
---	----	-----	-----------------------	--------	--------	------	-----------

- Room-based controllers will be sized on both electrical capacity and number of zones—this will affect control design.
- Requires communication—either wired or wireless—between the controller, sensors, and luminaires.
- Spaces with many different fixture types and many custom or outlier fixture types may make finding retrofit kits more difficult.

Retrofit kit with LLLC, centrally networked	15	70%	2.03 kWh 6.92 kBtu	\$0.22	\$2.45	11.0	\$196,785
---	----	-----	-----------------------	--------	--------	------	-----------

- Economies of scale play a role; technology is more cost effective as the building size increases.
- Allows for more lighting control strategies than other options.
- If a digital system is selected, diagnostics or other information can queried from the system.

Retrofit kit with LLLC, centrally networked with HVAC integration	15	70% lighting 20% HVAC	4.03 kWh 13.74 kBtu	\$0.44	\$2.82	6.4	\$123,889
---	----	--------------------------	------------------------	--------	--------	-----	-----------



Q&A



» Continuing Education Credit

GPG webinars offer 1 Continuing Education Learning Unit through the American Institute of Architects. GSA attendees are eligible for 1 Continuous Learning Point (CLP).

To receive credit:

Complete the post-webinar email survey. If you don't receive the survey, reach out to Donna Creason, donna.creason@gsa.gov.

GPG Webinar 31: LED Lighting and Controls Guidance

donna.creason@gsa.gov [Switch account](#) 

** Indicates required question*

Email *

Your email

For GSA Only: Continuing Education Credit

Check here to request a certificate for 1 GSA Continuous Learning Point (CLP).
 Members of the American Institute of Architects are eligible for 1 health, safety and wellness credit. If requesting AIA credit, enter your AIA number below.

American Institute of Architects Credit

Members of the American Institute of Architects are eligible for 1 health, safety and wellness credit. If requesting AIA credit, enter your AIA number below.

Your answer

First and Last Name *

Your answer

The information presented in the webinar was helpful. *

1 2 3 4 5

Strongly Disagree Strongly Agree

Thank you!



For more information: gsa.gov/GPG

Michael Myer, Pacific Northwest National Laboratory, michael.myer@pnnl.gov 509-375-7292

Andrea Silvestri, GSA Green Proving Ground, andrea.silvestri@gsa.gov 510-596-2000 x2

» Dimming

- The driver determines the dimming method.
- All equipment on the same wiring needs to use the same dimming method.
- The quality of dimming varies with drivers and dimming protocols.
- Consider for open-plan offices, private offices, and conference rooms. Avoid in spaces with low or infrequent use.
- Equipment may flicker when dimmed.
- Dimming is separate from communication protocols.

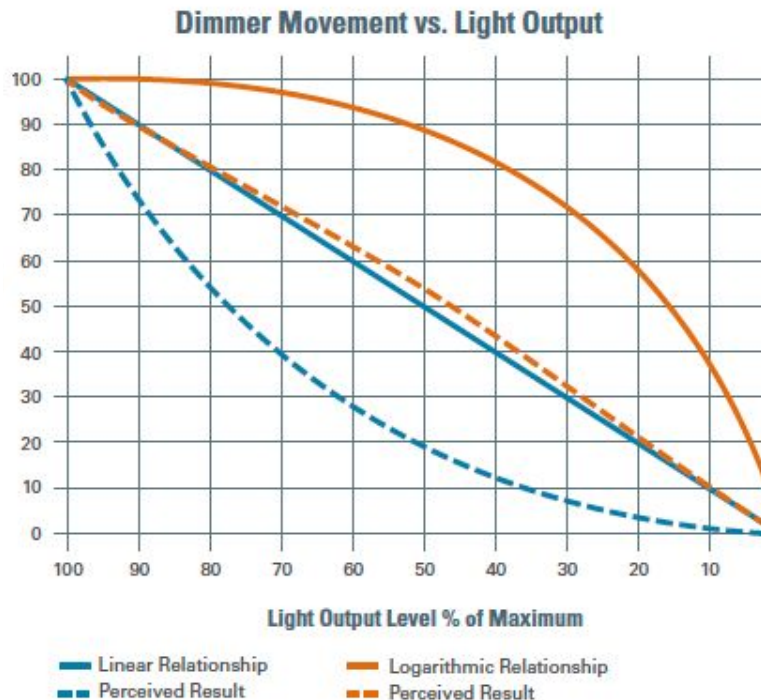

Light Output Compared to Perceived Results for 0–10V and DALI

» Dimming is Separate from Communication Protocols

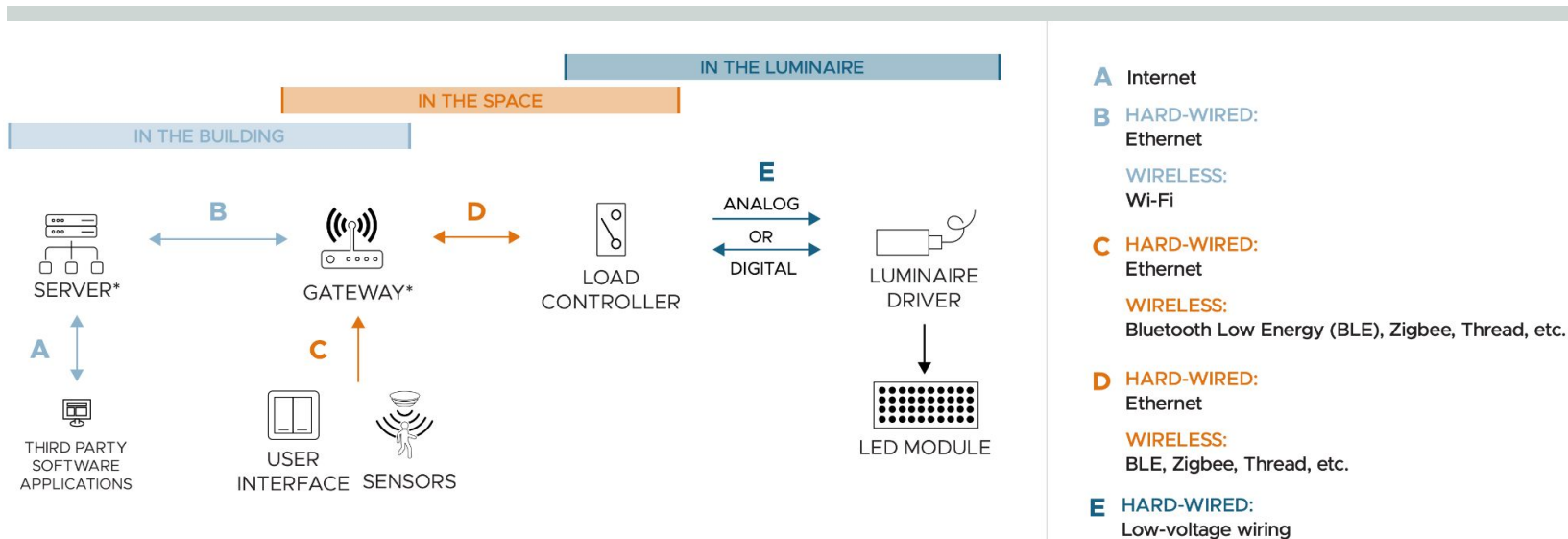

*In most systems, the gateway or a local server will act as the central controller.

Not all systems will require a connection to external applications or other building systems via a gateway or server. In some systems, the load controller may be integral to the driver, the sensors, or the user interfaces.

Analog (one-way) - 0-10V
Digital (two-way) - DALI 2, DMX 512, manufacturer specific, etc.

» Stand-Alone Control

- Consider for low occupancy and transitory spaces and enclosed spaces like private offices.
- Typically cheaper, less complex and easier to modify or change and do not require firmware upgrades
- Allows for easy visual tracking of installation when they are wired directly
- A wall-mounted vacancy sensor (manual on/off with automatic off sensor if occupant forgets to turn off the lights) that is wired to the fixtures can meet code requirements and be cost effective.
- Additional energy savings and other benefits are limited

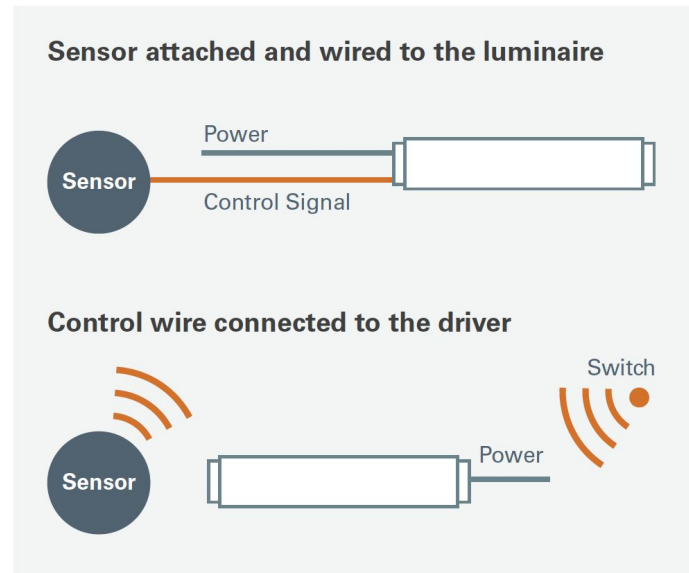

Wired and Wireless Stand-Alone Control Systems

» Room-Based Control

- Consider in spaces where more than 5 people will be at the same time and no system integration is needed
- Can be extended in the future
- Require a system that allows for commissioning,
- Consider communication protocols carefully
- Specify a room-based module that can accommodate at least 20 amps of load

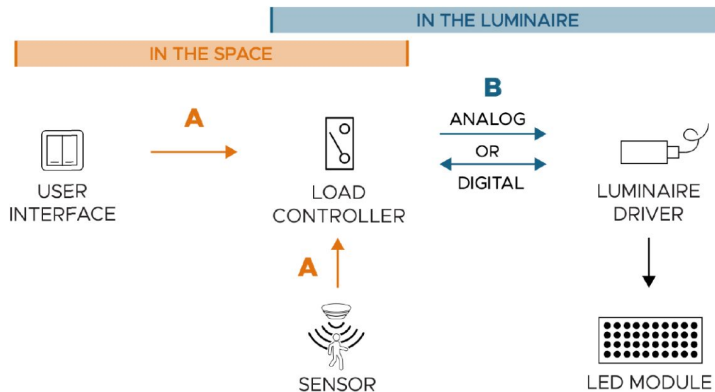

A HARD-WIRED:
Ethernet

WIRELESS:
BLE, Zigbee, Thread, etc.

B HARD-WIRED:
Low-voltage wiring

Analog (one-way) - 0-10V
Digital (two-way) - DALI 2 (including D4i drivers), DMX 512, manufacturer specific, etc.

Room-Based Control System
(Pacific Northwest National Laboratory)

» Centrally Networked Control

- Consider in spaces where more than five people will be at the same time and you can integrate with the HVAC or respond to demand charges
- Buildings over 50,000 ft² are ideal
- Requires digital drivers
- Ensure proper commissioning
- Avoid operating in “island” mode
- Can compensate for overlighting

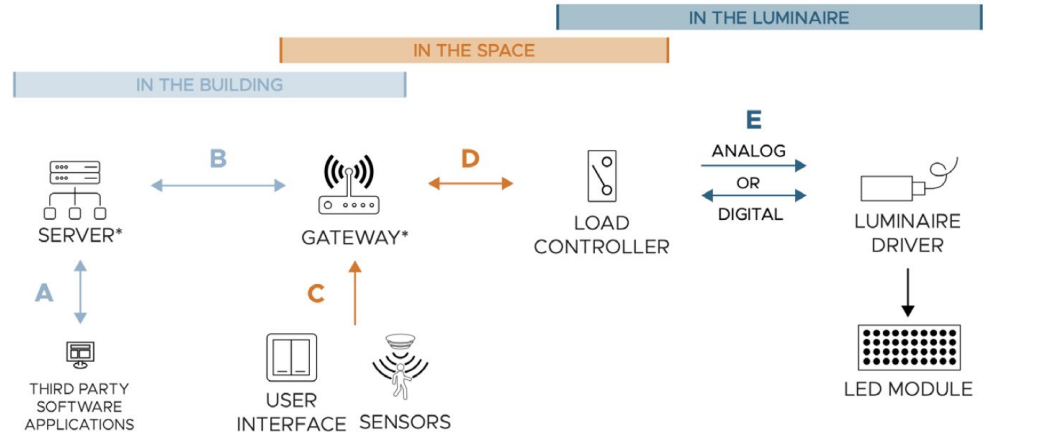

Centrally Networked Control System
(Pacific Northwest National Laboratory)

- A** Internet
- B** HARD-WIRED: Ethernet
WIRELESS: Wi-Fi
- C** HARD-WIRED: Ethernet
WIRELESS: Bluetooth Low Energy (BLE), Zigbee, Thread, etc.
- D** HARD-WIRED: Ethernet
WIRELESS: BLE, Zigbee, Thread, etc.
- E** HARD-WIRED: Low-voltage wiring

» Network Topologies



Hub: Central access point sends and receives signals from other nodes. For a wireless system, install the hub in a location that will provide radio frequency coverage for all the devices communicating with it. For a wired system, locate the hub in a location that minimizes wire runs or wire run challenges.



Mesh: All devices communicate with each other, and redundant paths exist to sustain communication when a single device fails. A mesh network can improve system resilience, increase the signal strength shared between devices, and increase the expanse of the network.

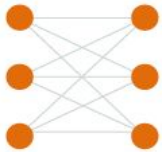

Point-to-Point: Typically limited to a single space. Point-to-point connections are often used within larger systems for communication between components or to incorporate battery-powered devices.

» 5. Luminaire-Level Lighting Control

- Consider for spaces that require more than 5 sensor and have daylight or variable occupancy
- Required for HVAC integration and other enhanced lighting capabilities
- Avoid in call centers, security rooms, and sensitive compartmented information facilities
- More sensors mean that each sensor has to be commissioned, about 30 minutes per luminaire
- Luminaire location determines the sensor locations, which may not be ideal
- Eliminates the need for separate sensor installation and power

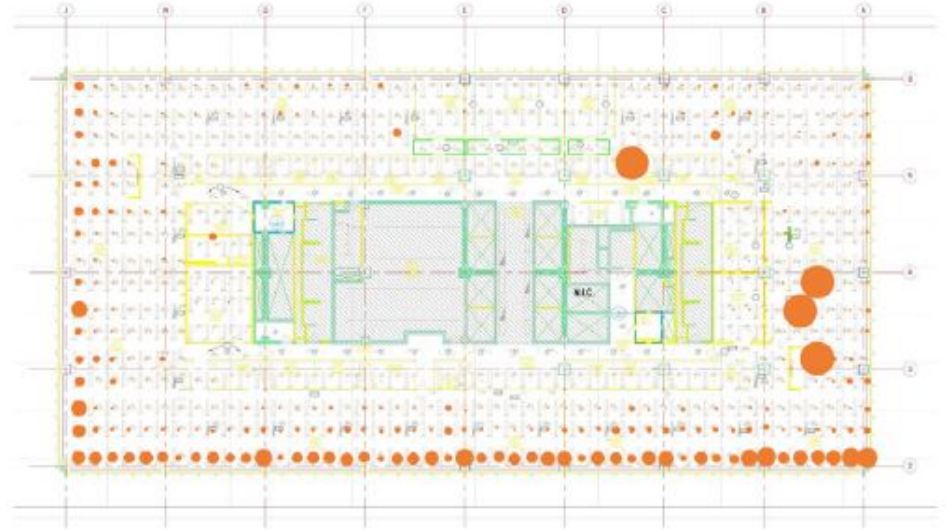

Large Circles Show that Sensors are Controlling Too Large of an Area (JCK, Chicago)

» 5. Zone-Based Control

- Consider for private offices, spaces that need fewer than 5 sensors, low-occupancy/high transitory spaces
- Zone-based control requires more labor to install than an LLLC system
- Wired communication is most common
- Wireless sensors can be used



Sensors are Mounted External to Luminaires in Zone-Based Control