



Prepared for the U.S. General Services Administration
by the National Renewable Energy Laboratory

MAY 2019

Case Study: Laboratory and Field Evaluation of Circuit- Level Submetering with an Integrated Metering System

**DYLAN CUTLER, WILLY BERNAL HEREDIA,
AND JESSE DEAN**

Disclaimer

This document was prepared as an account of work sponsored by the United States Government. While this document is believed to contain correct information, neither the United States Government nor any agency thereof, nor the National Renewable Energy Laboratory, nor any of their employees, makes any warranty, express or implied, or assumes any legal responsibility for the accuracy, completeness, or usefulness of any information, apparatus, product, or process disclosed, or represents that its use would not infringe privately owned rights. Reference herein to any specific commercial product, process, or service by its trade name, trademark, manufacturer, or otherwise, does not constitute or imply its endorsement, recommendation, or favoring by the United States Government or any agency thereof, or the National Renewable Energy Laboratory. The views and opinions of authors expressed herein do not necessarily state or reflect those of the United States Government or any agency thereof or the National Renewable Energy Laboratory.

The work described in this report was funded by the U.S. General Services Administration under Contract No. DE-AC36-08G028308.

Acknowledgements

GSA Region 8: David Marshall, Tyler Cooper

Enertiv: Sharad Shankar, Mark Pando

Mountain Energy Partnership (MEP): Ed Hancock, Greg Barker, Paul Norton

For more information, contact:

Dylan Cutler

Senior Research Engineer

National Renewable Energy Laboratory

Phone: (303) 275-3873

Email: dylan.cutler@nrel.gov

GSA's Proving Ground (GPG) program enables federal and commercial building owners and operators to make sound investment decisions in next generation building technologies based on their real-world performance.

Executive Summary

Circuit-level analytics and submetering platform (CLASP) technologies provide the ability to monitor individual circuits within an electrical panel in a building, providing detailed power and energy consumption data at a much more granular level than was previously achievable in a cost-effective manner. While the fundamental hardware components of CLASP—split core current transformers (CT) and power monitoring meters—have existed for some time, the new offerings in the market have effectively integrated these components and have streamlined data organization, transport, and access via software solutions accessible through web and application programming interfaces.

Building owners and operators typically have a difficult time accessing granular data on electrical power and energy consumption within the building. They may have access to whole-building electrical data via advanced metering infrastructure (AMI), but very rarely do they have insight into the power and energy consumption of individual end uses or devices. This lack of visibility into electrical data limits the ability to identify issues with individual pieces of equipment, quantify consumption of specific end uses or tenants, or present occupants with accurate data about their own energy consumption as building users. CLASP allows for various innovative use cases, such as tenant billing, tenant engagement, measurement and verification (M&V), equipment-level benchmarking, automated fault detection and diagnostics (FDD), condition-based maintenance, identification of energy conservation measures (ECM), time of use management, and demand response.

Evaluation of this technology focused on four aspects of the CLASP technology: (1) accuracy of the data provided by the system, (2) ability of the data to be used to drive energy savings, (3) ease of installation of this technology and ease of data integration into existing GSA analytics platforms, and (4) cost-effectiveness of the technology.

The CLASP technology was tested in a laboratory setting on a residential panel at the National Renewable Energy Laboratory (NREL), as well as in a field deployment where it was installed in a variety of electrical panels in the Salt Lake City courthouse, Utah. The field demonstration portion of the project focused on the evaluation of a data center—and all associated loads—as these spaces have significant, continuous loads and are typically billed separately to customer agencies in U.S. General Services Administration (GSA) buildings. Therefore, CLASP offers the ability to both bill tenants based on actual consumption of the data centers (as opposed to calculated consumption as currently done) and identify opportunities for energy savings in these high-energy-consuming end uses.

We show that CLASP was able to provide high-resolution, accurate power and energy consumption data during this demonstration, supporting the potential value propositions outlined above. Total energy error was <5%, and power percent error was <7% [with a root mean squared percent error (RSMPE) of <1%]. This met the goals outlined for accurate in-field consumption data. We note that these results are based on data acquired *after* the original CTs that were shipped with the CLASP were swapped out for high-accuracy CTs. Especially important for electrical circuits with low power factor, these CTs reduced the error associated with phase angle shift (see Section III.A) and improved data accuracy for the system. The original CTs were not designed to minimize phase angle shift, resulting in reduced accuracy on the monitored circuits due to significant inductive load from the computer room air conditioning (CRAC) unit compressor and fan motors.

The specific performance criteria outlined for this demonstration, as well as success criteria and results of testing, are outlined in Table ES-1.

Table ES-1: Performance Objectives

Quantitative Objectives	Metrics and Data Requirements	Success Criteria	M&V Results
Submeter accuracy in laboratory environment	1-minute interval data for power (kW) and energy (kWh)	Measurement accuracy of +/-1% at full range	Did not meet criteria for most tests
Submeter accuracy in field demonstration	1-minute interval data for power (kW) and energy (kWh)	<ul style="list-style-type: none"> • Measurement accuracy of energy consumption (as cumulated over 4-week period) of +/-10% • Measurement accuracy of +/-10% for total power measurements¹ • 99.9% data availability over the course of the demonstration 	Met: Total energy error was <5%, power percent error was <7% with RSMPE <1%
Energy savings from actions driven by CLASP data	Calculated energy savings from actualized ECMs	Measurable tenant load reduction for at least one end use	Met: Saved ~10% of server room heating ventilation and air-conditioning (HVAC) load
Qualitative Objectives			
Ease of installation and integration with GSA information technology (IT)/enterprise systems	<ul style="list-style-type: none"> • Level of technical expertise required • Time required to install and configure • Customer labor associated with install • Data integration requirements • Security requirements • Ease of visualizing and downloading data 	<ul style="list-style-type: none"> • Ability to be installed in most of GSA's electrical panels • Generally applicable to >70% of GSA facilities • Ability to integrate into GSA Link infrastructure 	Met: Successfully and efficiently installed in a variety of panels (demonstrating wide applicability); demonstrated integration into software components of GSA Link

¹ Accuracy values in product literature were developed using controlled voltage/current sources and are not reflective of in-field operation and, therefore, were not appropriate to use as the success criteria for this objective.

Quantitative Objectives	Metrics and Data Requirements	Success Criteria	M&V Results
Value proposition and cost-effectiveness	<ul style="list-style-type: none"> • Installation and operations and maintenance (O&M) cost • Energy and cost savings identified • Value of tenant billing • Value of fault detection and diagnostics 	<ul style="list-style-type: none"> • Potential savings exceeds expected installation and O&M maintenance costs • Software offers measurement and analytics capabilities • Determining if life cycle is cost-effective as a standalone platform 	Met: Life cycle is cost-effective for this demonstration and provides measurement and analytics capabilities

Figure ES-1 shows the time series data for a single monitored device (a CRAC unit) in the field demonstration. This figure demonstrates how well CLASP was able to track the power signal of the device—as compared to the revenue-grade submetering installed by NREL (green trace)—and demonstrates the improved accuracy obtained by switching from standard CLASP CTs (blue trace) to high-accuracy CTs (red trace).

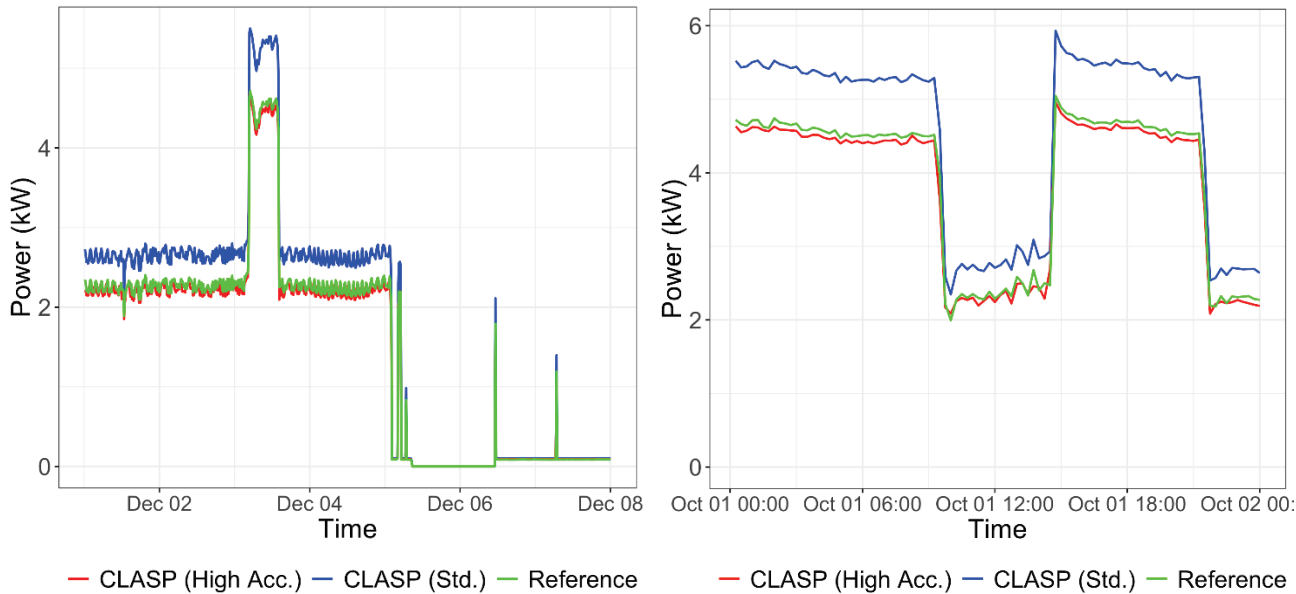

Figure ES-1. Accuracy results for a CRAC unit monitored in the field demonstration. One week of data are shown in the left figure and a single day in the right figure.

The data obtained from the CLASP were utilized in a detailed energy audit of the data center and identified an issue with the lead/lag programming of the three CRAC units. The building manager at the Salt Lake City courthouse addressed this programming issue with his staff and continued monitoring showed approximate energy savings of 10% of HVAC load in the data center. These results highlight the ability of this technology to be able to identify energy conservation measures and monitor the savings delivered by addressing those issues.

Finally, we demonstrated data integration from the CLASP system into the primary software component on the GSA enterprise level energy management and information system: GSA Link. Data from the CLASP were integrated into this platform and used to perform fault detection and diagnostics. This demonstrates the ability of CLASP to augment existing energy management and information systems in buildings where GSA Link is deployed, as well as to provide a pathway for delivering fault detection and diagnostics at other buildings throughout the portfolio. This integration approach would allow GSA to train staff on—and maintain—a single user interface to all of the time series data being acquired from the buildings, standardizing on enterprise software such as GSA Link.

This technology was shown to be easy to install by a licensed electrician, completing the install of five complete electrical panels (along with associated commissioning) at the Salt Lake City courthouse in less than one day. The technology was installed in high- and low-voltage panels and with limited space in the electrical room, demonstrating the applicability of this technology to almost all commercial buildings in the GSA inventory. Primary considerations for this technology include: appropriate pairing of CTs with meters for billing applications, selection of loads/circuits/panels that are of high value for detailed submetering (e.g., tailor for high-load devices, specific customer agency billing), and integration of these data with GSA's existing energy management infrastructure. There is an opportunity for widespread deployment in the GSA portfolio.

Table of Contents

- EXECUTIVE SUMMARY** **2**

- I. INTRODUCTION** **7**
 - A. WHAT WE STUDIED 7
 - B. WHY WE STUDIED IT 8

- II. EVALUATION PLAN** **10**
 - A. EVALUATION DESIGN..... 10
 - B. TEST BED SITE 14
 - C. METHODOLOGY 16

- III. DEMONSTRATION RESULTS** **20**
 - A. QUANTITATIVE RESULTS..... 20
 - B. QUALITATIVE RESULTS..... 30
 - C. COST-EFFECTIVENESS 33

- IV. SUMMARY FINDINGS AND CONCLUSIONS** **38**
 - A. OVERALL TECHNOLOGY ASSESSMENT AT DEMONSTRATION FACILITY 38
 - B. LESSONS LEARNED AND BEST PRACTICES 39
 - C. DEPLOYMENT RECOMMENDATIONS..... 40

- V. APPENDIX** **41**
 - A. MANUFACTURER CUT SHEET..... 41

I. Introduction

A. WHAT WE STUDIED

This report evaluates a hardware/software technology solution that provides circuit-level electrical submetering (CLASP) in buildings. This technology was tested in a laboratory setting, as well as in a field deployment where it was installed in a variety of electrical panels in the Salt Lake City courthouse in Utah.

CLASP is a fast-growing technology area. New products continue to be developed that allow building owners and operators to gain increased insight into the end-use electrical consumption of their facility at significantly reduced costs as compared to the incumbent technology and approaches. CLASP technologies typically use split-core current transformers (CTs) to measure the current flowing through the electrical wiring and voltage probes to measure the source voltage at the panel level. Readings from the CTs are typically combined with voltage readings from the electrical panel to calculate power consumption of the devices, and these data are transmitted to a data historian that is hosted either locally or in the cloud. Data transport methodologies vary—methods include Wi-Fi, cellular, and ethernet—and systems keep varying amounts of data locally on hardware or bridges as a buffering mechanism for any network interruptions in delivering data to the larger data historian. These data are then made accessible to the user through a user interface of some sort, typically a web interface. Web interfaces provide a variety of data analytics offerings, ranging from simple data access/visualization to development of rule-based alarms to complex benchmarking and fault detection and diagnostics algorithms. Notifications and reports generated from the acquired data can be configured to be automatically sent to operators or management. Many companies also support programmatic access to the data via an application programming interface (API).

The CLASP technology analyzed in this study was the EnertivTwo circuit monitoring system developed by Enertiv. This system provides a compact meter and data storage device that is integrated into a National Electrical Manufacturers Association (NEMA)-rated enclosure and can monitor up to 42 separate input channels. Table 1 shows the specifications for the technology, including quantities measured and measurement frequency.

The CLASP system is typically mounted adjacent to the electrical panel where individual loads or circuits are to be measured and connected to the panel via metal conduit. Split-core CTs are installed in the electrical panel, fed through the conduit, and interfaced with the circuit monitoring board via pre-wired quick connects. Voltage taps are connected from the monitoring system to the electrical panel and provide voltage measurements for the power calculations, as well as power the monitoring system. The system then transmits 1-minute (min) data to the cloud, where the data are stored and made accessible (downloadable at varying time resolutions) through the system's web-based analytics platform. The system also supports a RESTful API for programmatic data access. This hardware and software suite represents a streamlined set of components where the data processing, calculations, and local data storage are all housed in a single, small form factor enclosure and where the installation is streamlined via the limited, plug-and-play components (Figure 1).



Figure 1: Sample CLASP installation configuration (left; source: Enertiv). Cloud analytics and front web (right; source: Enertiv).

Table 1: EnertivTwo Specifications

Characteristic	Service Type
Service Type	Single phase, 3 phase – 4 wire (WYE)
Measurement Type	Current (A), voltage (V), power factor, frequency (Hz), power (kW, kVA, kVAR)
Input Channel	42
Sampling Frequency	500 kHz
Update Rate	1 second
Storage	3 months of offline data storage on the meter

B. WHY WE STUDIED IT

Building owners and operators typically have a difficult time accessing granular data on electrical power and energy consumption within their building. They may have access to whole-building electrical consumption data via advanced metering infrastructure (AMI), but very rarely do they have insight into the power and energy consumption of individual end uses. This lack of visibility into electrical data limits the ability to identify issues with individual pieces of equipment, quantify consumption of certain end

uses or tenants, and present occupants with accurate data about their own energy consumption as building users.

CLASP provides the ability to monitor power at each electrical circuit in the building, providing insight into different end-use consumption (e.g., plug loads, lighting loads, or HVAC), specific device-level consumption, or the floor- or panel-level consumption within a building. CLASP allows for various innovative use cases such as tenant billing, tenant engagement, measurement and verification (M&V), automated fault detection and diagnostics (FDD), identification of energy conservation measures (ECM), time of use management, and demand response. A listing of each end use and a brief description is provided in Figure 2.

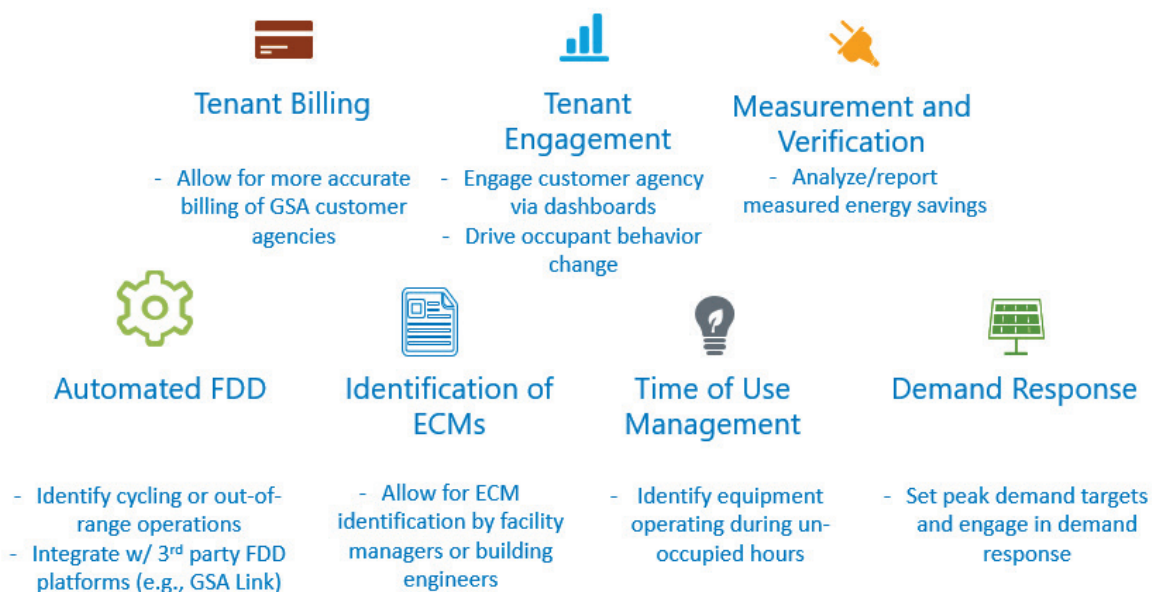

Figure 2: CLASP value propositions

CLASP does not save energy directly but rather is an enabling technology that allows for much more thorough and comprehensive energy management than is possible without the insight it provides. The enhanced visibility of specific end use or device-level energy consumption and the analytical insights provided by this technology promise to be more granular and scalable than data delivered by traditional submetering.

Standard approaches to submetering in buildings have been either a tailored AMI deployment or custom installations of circuit-level submetering. AMI is typically installed at the whole-building or large end-use (e.g., chiller plant) level and utilizes utility-grade solid-state meters. Federal agencies and other large organizations have been working on installing electrical meters and associated communications and data storage equipment as a part of AMI deployment for a number of years. AMI installations at federal facilities typically consist of installing a revenue grade whole-building interval electrical meter, gas meter, steam meter, or water meter that collects 15-min or 1-hour (hr) interval data. The data from the AMI meters are communicated through a local area network (LAN), the building automation system (BAS), radio frequency, or wireless network communication to a central database. The high cost of deploying AMI and its applicability to individual large loads does not allow for detailed submetering within a building. The incumbent approach to submetering specific loads within a building has been to

build up a system from individual components—including CTs, meters, data loggers, and data communications devices—and install it for the loads under consideration. Traditionally, this approach has led to high costs on a per-point basis and does not easily scale to measure all loads within a building(s). The new developments in CLASP—both streamlined or integrated hardware and data hosting/analytics solutions—are driving costs down and warrant investigation into the quality and cost-effectiveness of these new solutions in the marketplace.

When evaluating the different value propositions CLASP offers (Figure 2), three main use cases were identified for evaluation by the U.S General Services Administration (GSA):

1. Evaluation of building energy performance and improvement in building operations, including identification of ECMs and FDD
2. Acquisition of accurate, high-resolution data and using those data as a driver for energy savings associated with occupant behavior change (e.g., tenant incentive programs)
3. Acquisition of accurate, high-resolution data for the purpose of tenant billing.

CLASP in general and the vendor technology specifically are at technology readiness level (TRL) 8.² The products have been tested in an operational environment, are at a complete design phase, and are available in the market. This demonstration effort will verify that the commercially available systems perform as expected in the field environment, supporting the transition to TRL 9.

II. Evaluation Plan

A. EVALUATION DESIGN

Evaluation of this technology focused on four aspects of the CLASP technology: (1) accuracy of the data provided by the system, (2) ability of the data to be used to drive energy savings, (3) ease of installation of this technology and ease of data integration into existing GSA analytics platforms, and (4) cost-effectiveness of the technology.

Accuracy

The evaluation of the data accuracy was assessed in two separate environments: in a controlled laboratory deployment in the Energy Systems Integration Facility (ESIF) laboratory at NREL and in a field deployment in a commercial building. In each of these cases, the CLASP was installed on circuits within an electrical panel(s) that captured a range of end uses as well as a range of power demand magnitudes. To quantify the accuracy of the data acquired by the CLASP, high-fidelity revenue-grade submetering was installed on the exact same set of circuits as the technology under evaluation. Data were simultaneously collected from the CLASP and the revenue-grade metering, allowing for assessment of the data accuracy provided by the system.

² https://www.energy.gov/sites/prod/files/em/Volume_I/O_SRP.pdf

Successful performance in the accuracy evaluation portion of this demonstration was evaluated via two quantitative objectives:

- Quantitative Objective 1: Submeter Accuracy in Laboratory Environment
 - Success criterion: The technology demonstrates the ability to operate within the manufacturer's specified accuracy range in a controlled laboratory environment.
 - Success metric: Measurement accuracy of +/-1% at full range.
- Quantitative Objective 2: Submeter Accuracy In Situ Field Demonstration and Associated Data Availability
 - Success criteria:
 - The technology demonstrates the ability to provide accurate energy and power data in the field, enabling quantification of tenant energy/power consumption and quantification of savings due to ECMs. Technology demonstrates purported data storage capabilities.
 - Success metric: Measurement accuracy of +/-10% for total power measurements.
 - The technology provides sufficient data availability to function effectively in a tenant billing system.
 - Success metric: 99.9% data availability over the course of the demonstration.

Energy Savings

The second aspect of this technology demonstration was evaluating the ability of the data provided by the CLASP to be used to drive energy savings. This is a challenging metric to test because there are many factors that play into whether energy savings are achieved after the acquisition of accurate data. Said another way, the data alone will not drive energy savings; actions must be taken to achieve any actual reduction in energy use.

Two steps were taken to ensure that we could test this objective (at this specific demonstration site). The first was to focus the deployment of the CLASP equipment on specific loads within the larger building. We selected two server rooms within the building and metered all of the loads associated with these data centers (HVAC and compute loads). This load category is of particular interest to GSA due to the fact that these are 24-hr loads that typically serve individual customer agencies within the building and are therefore billed as “overtime utilities.” Overtime utilities billing has specific calculation algorithms but is not currently based on actual measured data. Application of the CLASP data to this equipment therefore provides two benefits: (1) the ability to bill accurately for the energy used within that space, and (2) the ability of customer agencies to pursue energy savings associated with this equipment in order to lower their—now data-driven—utility bills.

The second step that we took to enable evaluation of the ability of this technology to assist in driving energy savings was to perform an audit of the server rooms. This audit was intended to replicate the type of audit that specific customer agencies could perform on their data centers to identify ECMs that would reduce their utility bill. This portion of the assessment was evaluated by objective 3:

- Quantitative Objective 3: Energy Savings from Actions Driven by CLASP Data
 - Success criterion: Measurable reduction of load in at least one end-use category associated with the data center audit.

- Success metric: Measurable load reduction of >5%.

Ease of Installation/Integration

The third goal of this demonstration was to evaluate the ease of installation of CLASP technology and to evaluate the ease of data integration into existing GSA analytics platforms. Ease of installation and ease of use are key considerations for energy submetering technologies because labor costs associated with installation and use may exceed the cost of the hardware. To assess this objective, NREL participated in the installation process for the submetering system, documented the level of effort and process that was taken for install, and interviewed the GSA staff or contractors installing the product.

Additionally, NREL worked with the GSA Link team to assess the ability for the CLASP data to be integrated into GSA's enterprise energy management and information system. GSA Link is an analytics platform that GSA uses to evaluate performance of their buildings, track issues, and initiate work orders for project execution. The ease of installation and integration was assessed via the following qualitative objective:

- Qualitative Objective 4: Ease of Installation and Ease of Integration with the GSA Link system
 - Success criterion: The ability of the technology to be installed in the majority of GSA's applicable electrical panels and the ability to be integrated into GSA Link architecture.

Cost-Effectiveness

The final evaluation criteria for this demonstration was an evaluation of the cost-effectiveness of the technology. Assessment of this criteria is challenging due to the fact—as noted above—that there are no energy savings directly related to the acquisition of high-quality data; these data must be acted upon to derive savings from this technology. Additionally, the opportunities for savings may be vastly different between different buildings or different equipment that is being measured using the metering technology (e.g., this technology may be installed in an extremely well-operated building and have limited opportunities for savings identification relative to a building that is running poorly).

To provide some insight into the cost-effectiveness of this technology, NREL evaluated the amount of savings that must be delivered to offset the technology cost. The cost savings analysis associated with the ECMs, which was established during the data center audit as an example of potential savings driven by the technology, is also presented.

- Qualitative Objective 5: Value Proposition and Cost-Effectiveness Analysis
 - Success criteria:
 - Technology demonstrates a clear value stream that would enable cost-effective installation and incorporation into GSA Link.
 - Technology demonstrates a clear value stream that would enable cost-effective installation and use as a standalone platform.

Table 2 summarizes the performance objectives for this demonstration.

Table 2: Performance Objectives and Success Criteria

Quantitative Objectives	Metrics and Data Requirements	Success Criteria	M&V Results
Submeter accuracy in laboratory environment	1-min interval data for power (kW) and energy (kWh)	Measurement accuracy of +/-1% at full range	Did not meet criteria for most tests
Submeter accuracy in field demonstration	1-min interval data for power (kW) and energy (kWh)	<ul style="list-style-type: none"> • Measurement accuracy of energy consumption (as cumulated over 4-week period) of +/-10% • Measurement accuracy of +/-10% for total power measurements³ • 99.9% data availability over the course of the demonstration 	Met: Total energy error was <5%, power percent error was <7% with RSMPE <1%
Energy savings from actions driven by CLASP data	Calculated energy savings from actualized ECMs	Measurable tenant load reduction for at least one end use	Met: Saved ~10% of server room HVAC load
Qualitative Objectives			
Ease of installation and integration with GSA IT/enterprise systems	<ul style="list-style-type: none"> • Level of technical expertise required • Time required to install and configure • Customer labor associated with install • Data integration requirements • Security requirements • Ease of visualizing and downloading data 	<ul style="list-style-type: none"> • Ability to be installed in most of GSA’s electrical panels • Generally applicable to >70% of GSA facilities • Ability to integrate into GSA Link infrastructure 	Met: Successfully and efficiently installed in a variety of panels (demonstrating wide applicability); demonstrated integration into software components of GSA Link
Value proposition and cost-effectiveness	<ul style="list-style-type: none"> • Installation and operations and maintenance (O&M) costs • Energy and cost savings identified 	<ul style="list-style-type: none"> • Potential savings exceeds expected installation and O&M costs • Software offers measurement and analytics capabilities 	Met: Life cycle is cost-effective for this demonstration and provides measurement and

³ Accuracy values in product literature were developed using controlled voltage/current sources and are not reflective of in-field operation and therefore were not appropriate to use as the success criteria for this objective.

Quantitative Objectives	Metrics and Data Requirements	Success Criteria	M&V Results
	<ul style="list-style-type: none"> Value of tenant billing Value of fault detection and diagnostics 	<ul style="list-style-type: none"> Determining if life cycle is cost-effective as a standalone platform 	analytics capabilities

B. TEST BED SITE

The location selected for this demonstration was the federal district courthouse in Salt Lake City, Utah. The site is a mid-rise office building of 10 stories, with electrical risers and dedicated electrical rooms for each floor (both emergency and standard electrical rooms). The building attained LEED Gold certification in 2015.



Figure 3: Salt Lake City courthouse. Sources: Google Earth (left); Jimmy Salasovich, NREL (right)

The CLASP technology was installed in three separate locations within the courthouse: (1) the second-floor electrical room that serves the server room on that floor, (2) the fourth-floor electrical room serving the server room on that floor, and (3) the penthouse motor control center. The penthouse location was critical because it captures the dry coolers and pumps that provide cooling to all of the server rooms and data closets throughout the building. This combination of CLASP allowed GSA to capture the loads of the two larger server rooms within the building, along with all associated HVAC loads. The two server rooms under evaluation are shown in Figure 4.



**Figure 4: Showing second-floor (left) and fourth-floor (right) server rooms.
Source: Dylan Cutler, NREL**

The following site-selection criteria were established as important criteria for an effective test of the CLASP technology and were used in selection of this site:

- Multi-tenant building
- Small commercial building—the metered area of the building should cover approximately 15,000 ft²
- One breaker panel in the building should be a main panel
- Preferably, one breaker panel will serve a data center
- The panels must be 120/208 V or 277/480 V three-phase
- Modern identifiable commercial three-phase breaker panels with non-constant load
- Well-mapped breaker panel circuits (i.e., requires no circuit tracing and has a current panel card)
- Breaker panel serving mixed-type loads (e.g., lighting and plug loads)
- Each circuit in the panel should serve only one tenant or one end-use type
- Panels must provide sufficient space for installation of CTs and must provide space to install a voltage tap (e.g., via a spare breaker)
- Electrical room must provide space for temporary installation of ancillary metering equipment for independent M&V
- Location of electrical panels should have good to excellent 4G wireless reception.

The demonstration site meets most of the recommended criteria, except that it is not a small building. Therefore, whole-building utility data were not able to be used for M&V, and one breaker panel was not the main panel for the building.

C. METHODOLOGY

Quantitative Study Design

To establish the accuracy of the CLASP, revenue grade submetering⁴ was installed alongside the submetering technology under test, and data were pulled from the two systems at the same frequency. This enabled comparison of power readings from the two different systems over an extended period of time. In this section, we describe both the laboratory and field-testing configurations, as well as the circuits studied and associated loads.

a Laboratory Testing Design

For the laboratory testing, the CLASP was installed in a residential panel within the Systems Performance Laboratory in the ESIF (see Figure 5). This panel has high-fidelity submetering of all the circuits permanently installed to assist with the research in the lab. This monitoring equipment was leveraged for the lab testing portion. The equipment consists of Ohio Semitronics PC5 watt transducers and metering class CTs. The 120-V circuits use the PC5, which is accurate to +/-0.5% (including combined effects of power factor, repeatability, linearity, and current sensor). The 240-V circuits use PC5 meters connected to metering class CTs (accurate to 0.3%).

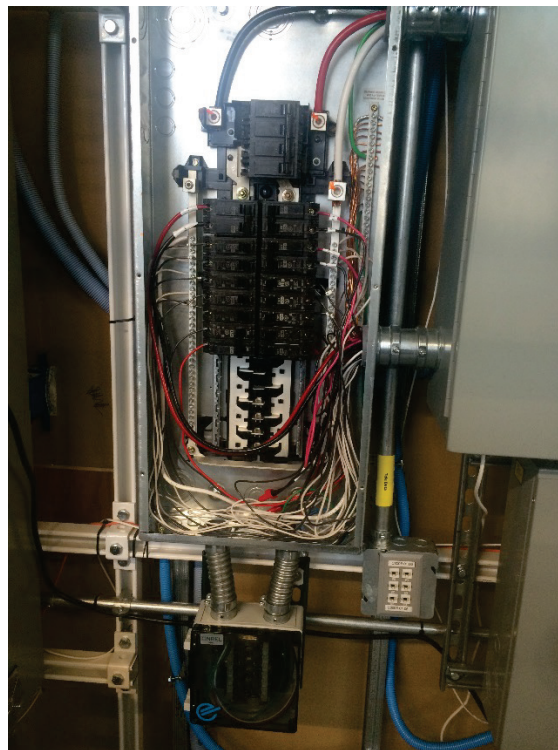

Figure 5: Electrical panel install for laboratory testing

The CLASP technology under test was installed to monitor eight circuits within the electrical panel. The panel layout and the associated circuits under test are shown in Table 3. Each of the measured devices were cycled on for 1-hr periods, and power and energy data were collected from both the CLASP technology and the high-fidelity laboratory metering at 1-min intervals over that period.

⁴ Revenue grade as defined in ANSI C12.1.

Table 3: Panel Schedule and Devices Monitored for Laboratory Testing

Measured	Device	Capacity (A)	Circuit			Capacity (A)	Device	Measured
Y	Range	50	1		2	30	Dryer	Y
			3		4			
Y	Refrigerator	20	5		6	30	Water Heater	Y
	Dishwasher	20	7		8			
	Garbage Disposal	20	9		10	20	N. Receptacles	
Y	Washer	20	11		12	20	Countertop Receptacles	
Y	Lighting	20	13		14	20	W/D Receptacles	Y
Y	240-V Lighting Outlets	15	15		16	15	Instrumentation	
			17		18			

b Field Testing Design

For the field demonstration, the CLASP technology was deployed to five separate panels in the Salt Lake City courthouse:

- Floor 2 - Panel H20E1:
 - CRAC 1: breaker 7, 9, and 11 (3P-40 A, 277/480 V)
 - CRAC 2: breaker 8, 10, and 12 (3P-40 A, 277/480 V)
 - CRAC 3: breaker 13, 15, and 17 (3P-40 A, 277/480 V)
- Floor 2 - Panel L2DOE1:
 - Server Bus (S): breaker 19, 21, and 23 (3P-125 A, 120/208 V)
 - Server Bus (N): breaker 20, 22, and 24 (3P-125 A, 120/208 V)
 - Panel L2OE1: breaker 25, 27, and 29 (3P-125 A, 120/208 V)
 - Panel L2OE2: breaker 26, 28, and 30 (3P-125 A, 120/208 V)
- Floor 4 - Panel H40E1:
 - DAC 4-5: breaker 1, 3, and 5 (3P-45 A, 277/480 V)
 - DAC 4-6: breaker 7, 9, and 11 (3P-45 A, 277/480 V)
- Floor 4 - Panel U40E1:
 - All (non-spare) circuits
- Pent House - Panel MCCOE
 - Dry Cooler 1, 2, 3, 4, and 5 (all circuits 3P-20 A, 277/480 V)
 - Dry Cooler Pumps 36, 37, 38, 39, 40, and 41 (all circuits 3P-20 A, 277/480 V).

On each floor, a 3G modem was deployed to communicate the data from the circuit-level submeter out to the cloud-hosted database for long-term data storage. This was connected with the meter via ethernet cable. Data were transmitted out to the vendor’s cloud-hosted database on 1-min intervals.

To assess the accuracy of the readings acquired by the CLASP, the three 3-phase circuits under observation in panel H20E1 had revenue-grade submetering technology deployed alongside the CLASP.

The revenue-grade metering technology that was used to assess the accuracy consisted of Continental Controls WattNode Revenue (RWNC-3Y-480-MB) combined with Continental Controls revenue-grade Accu-CTs. The Accu-CTs provide accuracy of 0.5% and are tested to ANSI C57.13, Class 0.6, in conjunction with the associated WattNode to ensure ANSI C12.1 accuracy. The WattNodes are connected to a Campbell Scientific CR-6 data logger via MODBUS communications, and data are communicated from that data logger out to a cloud-hosted database via cellular communications. Data were collected at 1-min intervals from the Campbell Scientific data logger. This configuration is shown in Figure 6.

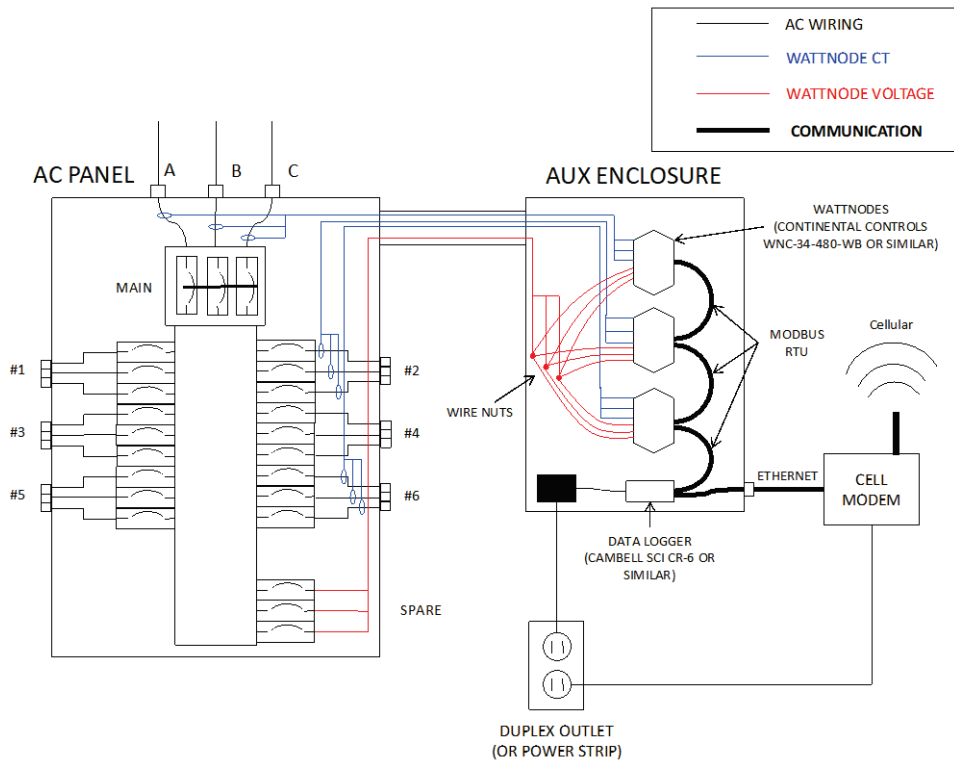

Figure 6: Diagram of NREL submetering configuration that was used to evaluate performance of the CLASP technology in the field demonstration (note that the three-phase panel pictured here differs from the residential panel pictured in Figure 5)

Final install of both the CLASP and revenue-grade metering is shown in Figure 7.



Figure 7: Installation in the second-floor electrical room. Panel H20E1 is shown in the center of each image (in progress on the left; completed install on the right). Source: Dylan Cutler, NREL

Qualitative Study Design

To assess the ease of installation for the CLASP system, NREL observed the electricians' process for installation during the 1½-day install. Informal interviews were carried out with the electricians after installation was complete.

To assess the ability to integrate effectively into the enterprise analytics platform GSA Link, NREL worked with GSA Link administrators to assess potential pathways for data integration. Additionally, NREL reviewed the set of standard fault detection and diagnostics rules that are deployed as part of the base GSA Link deployment during a new install. This provided a qualitative review of what categories of rules the CLASP data would be able to assist in addressing, what categories of rules these new data would enable, and what categories of rules these data would not be able to address sufficiently.

Data Analysis

Data from the CLASP system were pulled via the vendor's application programming interface on 1-min intervals. Similarly, the data from the revenue-grade submetering were pulled down from the loggernet website in 1-min intervals. These data were aligned on timestamp, such that the value at each timestep could be compared between systems.

To calculate the accuracy of the power and energy readings from the CLASP system, bias and normalized bias (or percent error) were calculated for every timestep during the observation period. The bias in between the two readings is defined as: $x_{meas} - x_{obs}$, where x_{meas} is the CLASP measurement and x_{obs} is the revenue-grade submetering. Percent error is defined as $(x_{meas} - x_{obs})/x_{obs}$. Both the bias and

percent error are then averaged over all timesteps and reported as the mean bias and average percent error. These values show whether the measurements were consistently high or low on an absolute and percent basis, respectively.

These errors were then summarized into a root mean squared percent error (RMSPE) to quantify the magnitude of the combined error in the measurements. RMSPE is defined as:

$$RMSPE = \sqrt{\frac{\sum_{i=1}^n \left(\frac{x_{meas} - x_{obs}}{x_{obs}} \right)^2}{n}}$$

Where n is the number of observations.

It was critical to use the RMSPE instead of simply the root mean squared error due to the variability in some of the loads. For highly variable loads, larger absolute errors can occur at higher loads where the actual percent error is exactly the same as at a lower load point. This fact skews the root mean squared error metric (as well as standard deviations), despite the fact that their accuracy on a percent basis is consistent across the measurements. Therefore, all errors were reported on a percent basis.

To assess the total uncertainty of the CLASP's measurements, it is necessary to account for the uncertainty of the reference sensor (provided by the manufacturer). The total uncertainty should consider the uncertainty of the reference sensor and the estimated uncertainty of the CLASP system with respect to the reference sensors:

$$Total\ Uncertainty_{CLES} = \sqrt{Uncertainty_{CLASP/REF}^2 + Uncertainty_{REF}^2}$$

III. Demonstration Results

This section describes the quantitative and qualitative results for both stages of the project: the laboratory testing and the field deployment. Section III.A presents the results for accuracy testing and the data center audit and associated ECM savings analysis. Section III.B presents the results for the qualitative objectives of ease of installation and ease of integration into GSA Link.

A. QUANTITATIVE RESULTS

Objective 1 (Quantitative): Submeter Accuracy in Laboratory Environment

As described in Section II.C., the CLASP was deployed on a single residential panel in the Systems Performance Laboratory in NREL's ESIF laboratory, and accuracy was assessed via a set of controlled 1-hr tests for each of the different appliances (as well as certain combinations of appliances). The readings from the CLASP were compared with the high-accuracy power monitoring equipment in the laboratory. The raw data from the CLASP and the laboratory power monitoring equipment were pulled at 1-min intervals. These data were also aggregated to 15-min data, and accuracy results were calculated for this coarser time resolution data. The 15-min aggregation was performed because the applications outlined for this study (e.g., tenant billing and fault detection) generally do not require finer resolution than 15-min data. This section presents the accuracy results from this testing.

The CLASP was able to track the dynamics and the magnitude of the loads quite closely during the laboratory testing. The quantitative results are presented for each of the eight 1-hr tests in Table 4 (accuracy results comparing the 1-min data) and Table 5 (accuracy results comparing the 15-min data). The error for total energy (for both the 1-min and 15-min data) is less than 4% for all appliances with the exception of lighting (240 V). For many of the loads, the error observed in the 15-min data is less than the 1-min data. This is due to the 1-min data being averaged up to 15-min intervals and therefore smoothing out some of the measurement error within that 15-min window. For many applications (e.g., billing), the 15-min data will be sufficient.

Table 4: Empirical Sensor Uncertainty (1-Min Data)

Trial	Appliance	Nominal Voltage (V)	Mean Power (W)	Mean Bias (W)	Average Percent Error (%)	RMSPE (%)	Total Energy Error (%)
1	Refrigerator	120	114.30	-1.84	-1.61	1.61	-1.61
2	Washer	120	115.38	4.88	4.60	11.49	4.23
3	Lighting (All)	120	530.53	-12.42	-2.17	3.09	-2.34
4	Lighting (240 V)	240	122.16	-23.16	-18.96	18.96	-18.96
5	Dryer	240	2,024.44	52.60	0.22	4.49	2.6
6	Water Heater	240	2,059.44	53.42	2.38	2.51	2.59
7	TV/DVD	120	103.95	-0.41	-0.87	4.65	-0.39
8	Range	240	1,056.91	12.36	10.79	14.31	1.17

Table 5: Empirical Sensor Uncertainty (15-Min Data)

Trial	Appliance	Nominal Voltage (V)	Mean Power (W)	Mean Bias (W)	Average Percent Error (%)	RMSPE (%)	Total Energy Error (%)
1	Refrigerator	120	114.28	-1.84	-1.61	1.61	-1.61
2	Washer	120	112.39	4.02	3.62	3.9	3.58
3	Lighting (All)	120	539.26	-12.51	-2.32	2.33	-2.32
4	Lighting (240 V)	240	122.16	-23.16	-18.96	18.96	-18.96
5	Dryer	240	2,102.59	57.76	2.68	2.69	2.75
6	Water Heater	240	2,079.18	54.06	2.41	2.44	2.6
7	TV/DVD	120	103.75	-0.42	-0.42	0.51	-0.4
8	Range	240	1,073.71	12.4	2.26	3.1	1.15

The ability of the CLASP to track the electric load profile was also evaluated by looking at the time series graphs of the power readings for the different devices. Figure 8 shows data for the electric range and dryer on the left and right side, respectively. One can observe the actual motor start currents in these graphs, which are typically smoothed out with other loads and not able to be analyzed by the building operator. For both loads, we can observe that the CLASP aligned very closely with the billing grade meter used as reference.

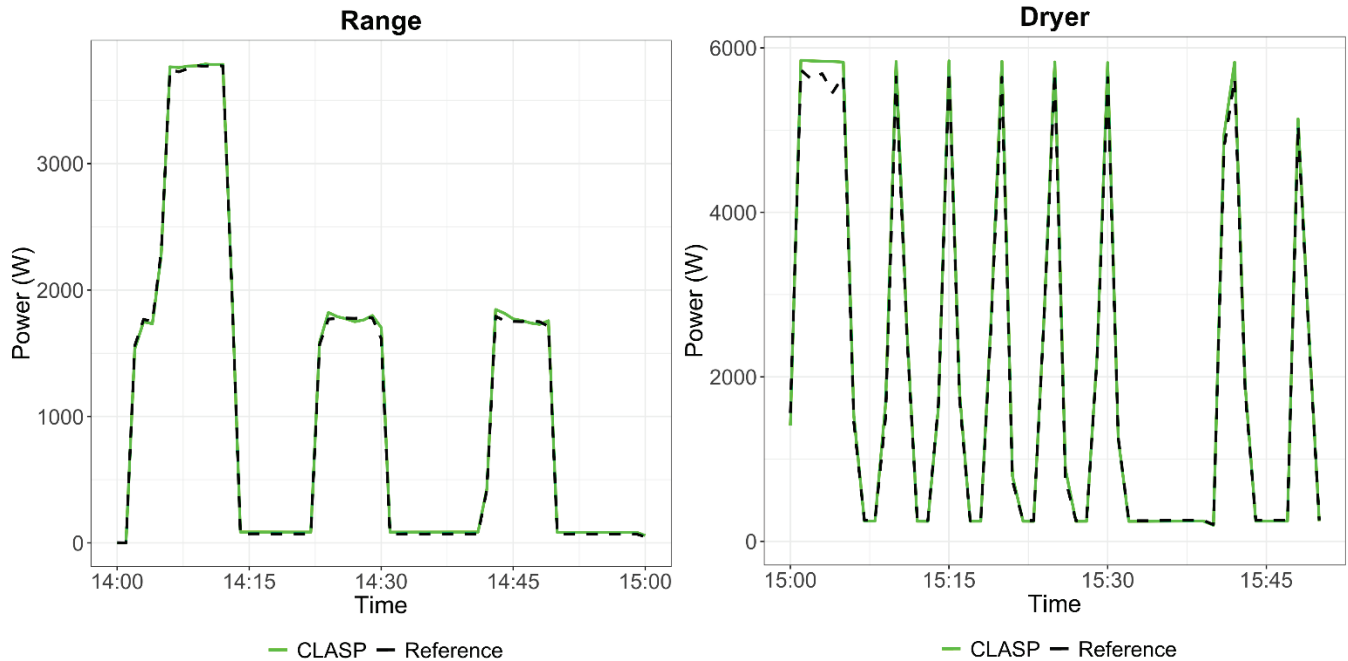

Figure 8: CLASP trial experiments: electric range (left); dryer (right)

Performance for the CLASP was consistent, except for the 240-V lighting test. For this load, the Enertiv meter underestimates the power consumption by almost 20%. The 240-V lighting measurement represents the load from the 240-V LED lighting fixture. Figure 8 shows the comparison between CLASP and the reference sensor for two low-power loads. Power factor readings were close to 1 for both cases.

The current draw on the lights is only half of the current draw on the TV-DVD because the lighting is a 240-V appliance. The other low-power appliances with similar average power (~100 W) draw approximately 1 A because they are all 120-V appliances. The 240-V lights are only pulling about 0.5 A. This level of current draw falls below the range of stated accuracy for their CTs because the CTs are rated at +/-1% accuracy from 1 A up to the rated capacity of the CT. Therefore, the 240-V lighting circuit does not appropriately test the accuracy of this system and can be excluded from our evaluation of accuracy of the system when operating within specifications. Most lighting circuits within a commercial building will have multiple light fixtures on each branch circuit and have a much higher current draw than 0.5 A.

The panel metered was representative of a residential panel according to its lower voltage and smaller loads. These laboratory experiments facilitated an initial assessment of the meters in a highly controlled environment and provided insights for the site deployment. However, the site deployment provided longer data collection and a more suitable environment for the technology, as the meters were designed with commercial applications in mind.

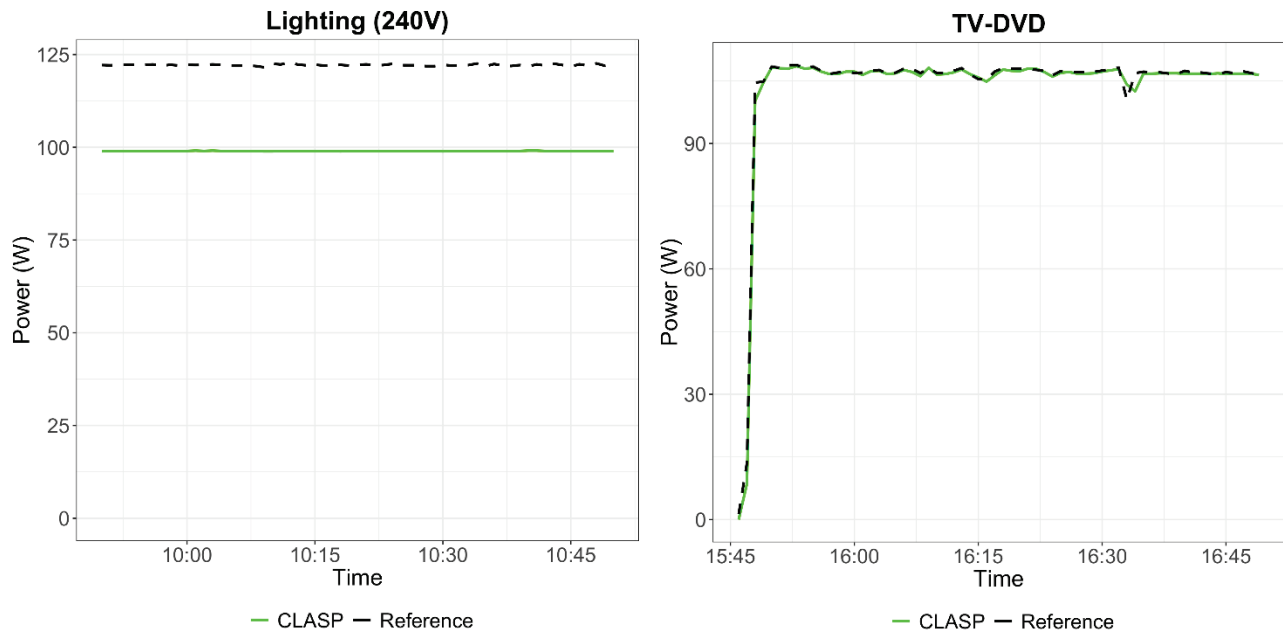

Figure 9: Low-power loads: lighting 240 V (left) and TV-DVD (right)

The loads operating in the expected operating ranges for the submetering system all presented total error of <4%. While only one of the tests (TV/DVD appliance test) met the objective criteria of error <+/- 1%, the system demonstrated high-quality time signal tracking, and error was maintained in the 1%–4% range. Other possible sources of error contributing to observed error could include inexact time synchronization between the two monitoring systems, error in the laboratory monitoring system, and phase angle shift from the CTs.

Because the error for a single measurement was calculated as the percent error between the two measurements for a single timestamp (e.g., 2018-04-01 14:01:00), if the system clocks were misaligned, then the average power (or energy) calculated over the last minute could be slightly different between systems. To address this source of error, the CLASP data were shifted 1 min forward and backward with respect to the laboratory measurements. If a reduction in error was observed by this 1-min shift (across tests), then this shift was maintained during error analysis to reduce the error possibly resulting from clock synchronization.

The accuracy of the laboratory system measurement infrastructure is 0.5% (see Section II.C.a). The combined uncertainty resulting from these two sources of error can be calculated by the quadrature of these two errors: $\sqrt{e_{lab}^2 + e_{submeter}^2} = \sqrt{0.005^2 + 0.01^2} = 0.0112$ (1.12%). Thus, the inclusion of the lab monitoring equipment error does not significantly increase the acceptable error that we could expect from the CLASP measurements.

Error introduced from the phase angle shift introduced by the CTs is discussed in Section III.A.b.

Objective 2 (Quantitative): Submeter Accuracy In Situ Field Demonstration

After laboratory testing, the CLASP system was deployed in a medium-voltage panel (277/480 V) within the Salt Lake City district courthouse. Accuracy analysis was performed on three 3-phase circuits, each powering an individual computer room air conditioner (CRAC) unit in the second-floor data center. In this section, results are presented for the initial deployment where the submetering system was

deployed with typical CTs. Results are also presented for the submetering system when paired with CTs tailored to reduce phase angle shift. Finally, an application of the CLASP data to an energy efficiency audit of the second-floor data center and the utilization of these data to confirm savings from implemented energy efficiency measures are discussed.

The initial install of the CLASP included the legacy CTs integrated with the meters. The readings showed higher discrepancies than observed in the laboratory testing. The meters were consistently overestimating the sensor readings by ~16% (see rows 1–3 in Table 6). Upon further analysis of the power quality associated with the three CRAC units under observation, it was noted that the power factor of the devices was very low (due to the high inductive load associated with compressor and fan motors), typically ranging from 0.5–0.7 power factor.

Current transformers can introduce a phase shift in the AC current signal (relative to the actual current) when monitoring loads with low power factors. This phase shift can result in incorrect power factor calculations by the submeter, which, in turn, results in incorrect real power calculations. At low power factors, the error caused by this phase shift is especially significant.^{5,6} As an example, a 4° phase angle shift at a power factor of 0.5 results in ~12.3% error in the calculated real power. Documented ranges of phase angle shift in standard CTs are 0.2–6°.

Table 6: Data Statistics for November 2017 (15-Min Data)

Trial	Appliance	Nominal Voltage (V)	Mean Power (W)	Mean Bias (W)	Average Percent Error (%)	RMSPE (%)	Total Energy Error (%)
1	CRAC 1 (Std. CT)	480	1,070.95	172.97	16.76	0.32	16.15
2	CRAC 2 (Std. CT)	480	1,623.84	264.41	16.29	0.31	16.28
3	CRAC 3 (Std. CT)	480	952.02	160.26	17.27	0.33	16.83
4	CRAC 1 (Accu-CT)	480	1,070.95	27.79	-3.71	0.7	2.59
5	CRAC 2 (Accu-CT)	480	1,623.84	-51.84	-3.13	0.06	-3.19
6	CRAC 3 (Accu-CT)	480	952.02	-16.2	7.21	0.14	-1.7

To evaluate whether the observed error was in fact associated with inaccurate real power calculations due to phase shift error, a decision was made to install higher-accuracy CTs specifically designed to limit phase angle shift to <0.5° to reduce this source of error. Accuracy results were significantly improved after installing these CTs, as shown in rows 4–6 of Table 6. Figure 9 shows a time series graph for one of the CRAC units, both for a full week (left graph) and a single day (right graph). The figure shows that while both types of CTs track the power signal very accurately, the higher-accuracy CTs eliminate the consistent, high offset of the standard CTs and produce much more accurate readings compared to the billing grade meter.

⁵ https://ctlsys.com/Measurement_Errors_Due_to_CT_Phase_Shift/

⁶ <http://www.magnelab.com/wp-content/uploads/2015/01/Ct-phase-shift-and-its-affect-on-power-factor.pdf>

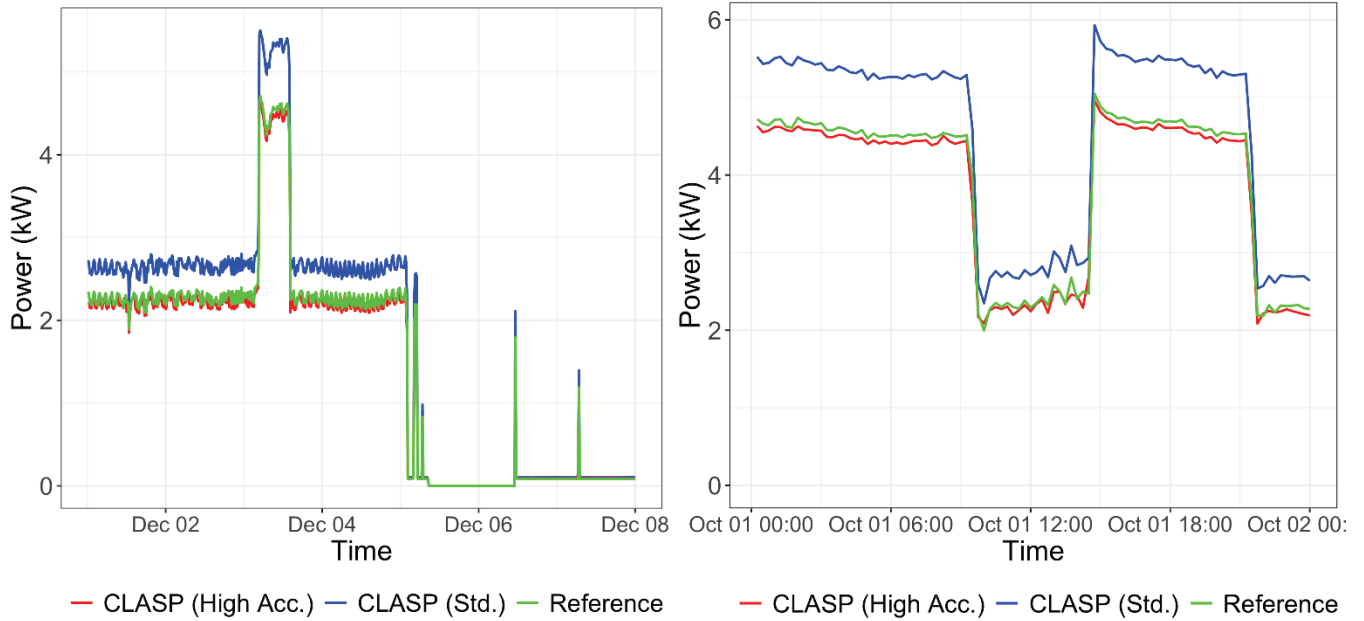

Figure 10: Vendor measurements vs. reference readings: week long (left) and day span (right)

The monthly energy consumption for each of the CRAC units was calculated, and the percent error between CLASP and revenue-grade submetering was calculated. The results for CRAC 1 are shown in Figure 11. The standard CTs consistently overestimated the monthly energy by 16%, while the Accu-CT configuration produced much closer results. This can be seen in October through December, where both the standard CTs and the improved CTs were compared to the benchmark data. Table 7 shows tabular results for energy errors by month.

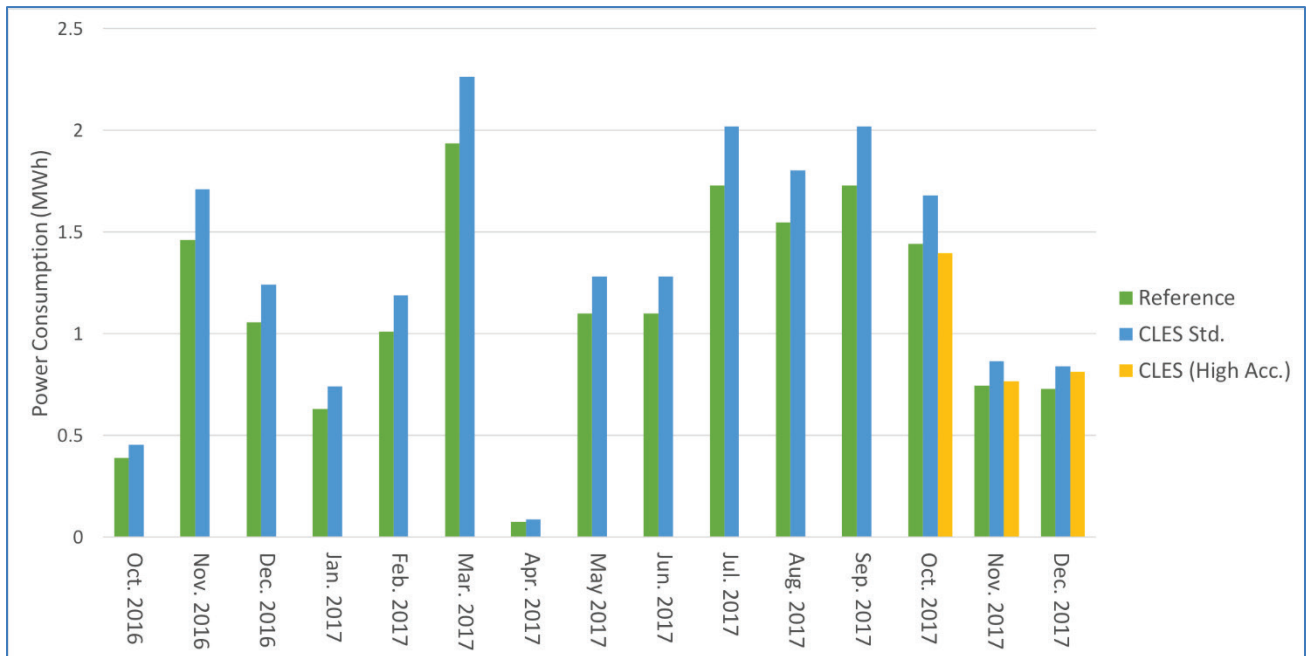

Figure 11: Monthly energy consumption for CRAC 1

Table 7: Total Energy Error

Equipment	2016			2017										
	Oct	Nov	Dec	Jan	Feb	Mar	Apr	May	Jun	Jul	Aug	Sep	Oct	Nov
CRAC 1 (Std. CT)	16.93	17.06	17.56	17.73	17.43	16.82	16.67	16.59	16.59	16.64	16.54	16.64	16.58	16.15
CRAC 2 (Std. CT)	15.85	16.25	16.48	16.3	16.1	15.72	15.86	15.88	15.88	15.83	15.87	15.83	16.3	16.28
CRAC 3 (Std. CT)	16.36	16.01	15.49	14.65	14.33	13.32	11.89	19.06	19.06	5.86	-11.76	5.86	16.96	16.83
CRAC 1 (Accu-CT)													-3.18	2.59
CRAC 2 (Accu-CT)													-2.99	-3.19
CRAC 3 (Accu-CT)													-1.64	-1.7

The results of the field demonstration portion of the testing met the performance objective of achieving <+/-10% error for both energy and power during the field deployment.

Objective 3 (Quantitative): Utilizing CLASP for Energy Savings

After meeting the success criteria for the accuracy verification phase, the ability of the meters to create an incentive for tenants to reduce energy consumption and quantify the value proposition of deploying the meters based on concrete ECMs attainable due to CLASP was assessed. This objective was tested by conducting an energy audit of the second-floor server room in the Salt Lake City courthouse.

The CLASP was deployed so that it could monitor all of the server rack loads, the CRAC units within the server room, and the dry coolers and pumps that serve the server room. Using these data, a power usage effectiveness (PUE) of 2.77 (over a full year of collected data) was calculated for the data center on the second floor and provided a baseline for energy saving opportunities. PUE is defined as the total data center annual energy divided by the total information technology (IT) annual energy—essentially a metric capturing how much energy was used to provide the computing capabilities of the data center. In this specific case, because we did not capture the lighting circuit for the server room, this would be classified as a mechanical PUE.

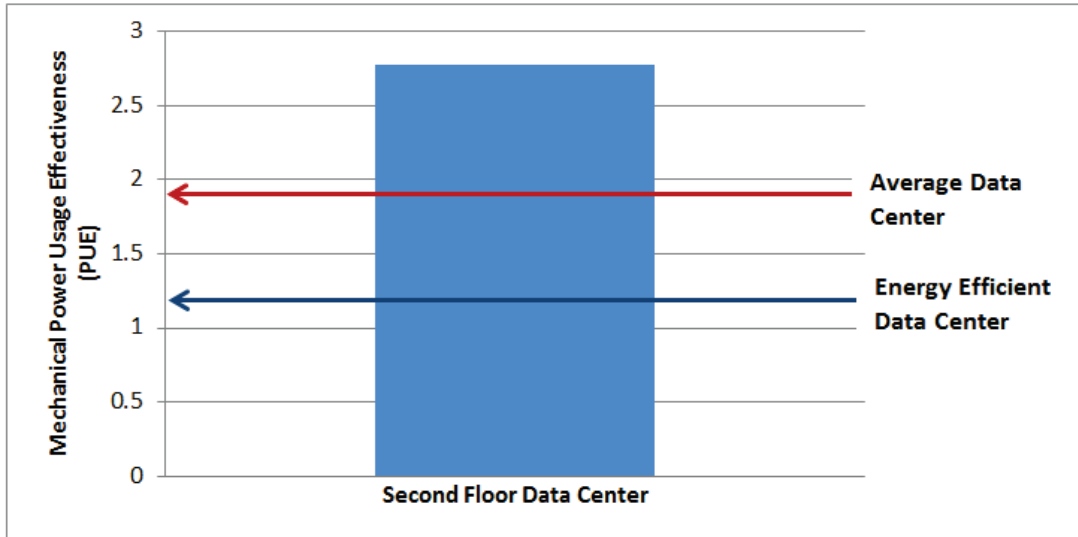

Figure 12: Calculated PUE for the second-floor server room

The audit was performed using a combination of data acquired during a one-day site visit and the data provided by the CLASP data audit. It can be noted that the data center professional who executed the study stated that he did not have access to this level of data to inform a data center audit in the past. The audit proposed three ECMs to address the energy savings:

1. Utilize wet bulb to control tower free cooling
 - a. Current control operating based on outside dry bulb temperature. It has been recommended to reprogram the unit to operate according to the wet bulb temperature because that dictates actual cooling tower performance.
2. Connect CRACs to building chilled water
 - a. Current chilled water plant runs continuously. It is recommended to disconnect from the dry cooler loop and extend to the mechanical room.
3. Reprogram CRAC units to coordinate their operation
 - a. CRAC units have “iCOM” controls that can be set up in “teamwork” mode.⁷ This change would coordinate the units to run one at a time (alternating lead weekly) with alarm/auto-start backup.

The first ECM was undertaken by the building staff to improve overall performance of the building chiller plant. The second ECM was considered, but it was decided that greater energy savings would be achieved by enabling the building to turn off the chiller plant during nighttime operation (which was the designed operation sequence). Therefore, it was determined that the CRAC units would continue to be connected to the dry coolers.

The third ECM was identified by the examination of the data provided by the CLASP data. It was noted during observation of the data that multiple CRAC units were cycling excessively and operating simultaneously (despite being sized such that a single 5-ton CRAC unit could meet the observed cooling

⁷ <https://www.dces.com/pdfs/SL-11961.pdf>

load). Figure 13 shows a single week of operation where the CRAC units are cycling, showing simultaneous operation, and operating at low loads.

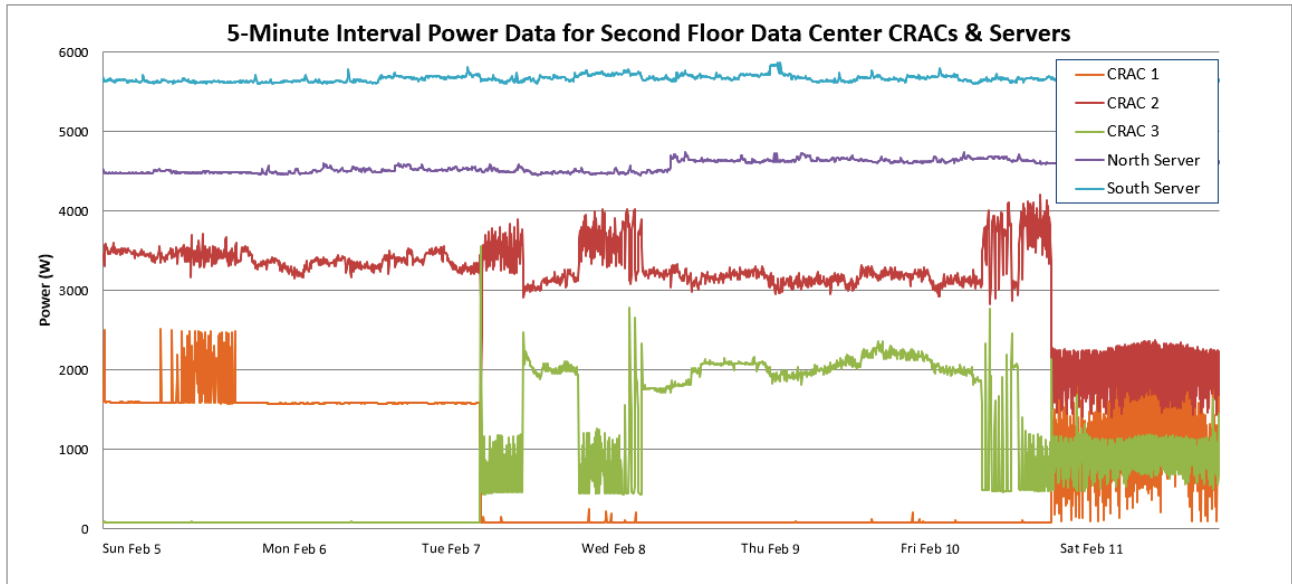

Figure 13: CRAC unit operation during a single week in February

The Salt Lake City courthouse facilities team addressed this ECM by coordinating the Liebert representative to come out and reprogram the CRAC units to work in a more efficient team mode, based on the assessment of the type of data presented in Figure 13. The CRACs were reprogrammed so that only a single unit would be on at a time (1 lead, 2 lag), whereas prior to ECM identification, two CRAC units were in lead at all times. This resulted in excess cooling capacity, low loading on the CRAC units, and excessive cycling of the CRAC units. The baseline and post-retrofit conditions are described in Table 8.

Table 8: ECM Description and Comparison

State	Description	Consequences
Baseline Condition	<ul style="list-style-type: none"> Set up for 2 leads and 1 lag 	<ul style="list-style-type: none"> Excess capacity versus load Reduced lifetime due to frequent cycling
Condition After Action	<ul style="list-style-type: none"> Set up for 1 lead and 2 lags 1 hr of effort In the event of high-temperature alarm, all lags kick on 	<ul style="list-style-type: none"> Reduced power consumption due to higher part load ratio Increased equipment lifetime due to reduced cycling

After completion of the CRAC reprogramming, the data were analyzed to establish energy savings derived from the execution of this ECM. NREL collected power consumption data and associated temperature data for one week prior to the reprogramming and one week after the reprogramming and assessed the percent savings from the reprogramming ECM. Figure 14 shows the data used for assessing the savings. These were then generalized into the data in Table 9 based on the linear regressions. The implementation of the data center ECMs resulted in a 9%–11% energy savings achieved across a wide temperature range.

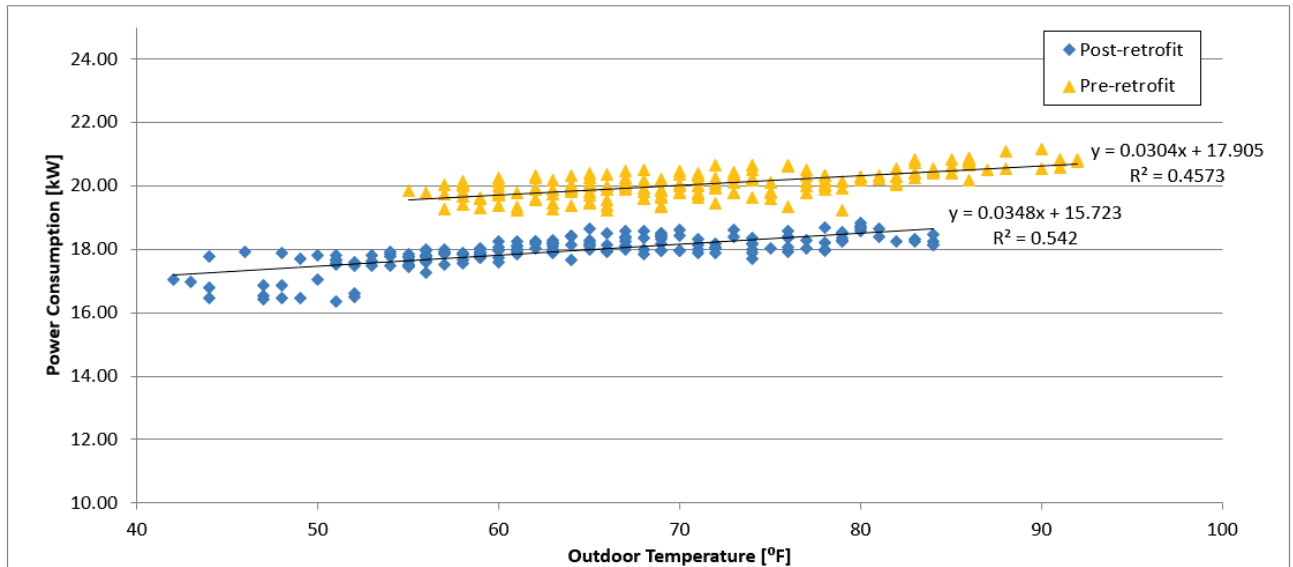

Figure 14: One-week comparison of the power consumption for the second-floor server room (pre- and post-retrofit)

Table 9: Energy Savings Based on Outdoor Temperature

Outdoor Temperature	40° F	50° F	60° F	70° F	80° F	90° F
Baseline Power (kW)	19.1	19.4	19.7	20.0	20.3	20.6
Post-Retrofit Power (kW)	17.1	17.5	17.8	18.2	18.5	18.9
Percent Savings (%)	11%	11%	10%	10%	9%	9%

B. QUALITATIVE RESULTS

Objective 4 (Qualitative): Ease of Installation and Ease of Integration with GSA IT

a Installation Summary

The CLASP technology evaluated in this report makes it easier to meter individual loads in a panel due to small form factor CTs, an integrated board/meter/enclosure, plug-and-play CT design, and pre-configured cloud-hosted data storage. The tested CLASP technology uses a conventional approach for metering loads; wired split-core CTs and voltage taps are required. It is imperative to organize and route

properly the cables for the CTs. The technology is applicable for any standard electrical panel and can be used with motor control centers and large-device disconnects, and it is anticipated to be suitable for wide adoption within GSA's facilities.

Installation of the voltage taps and CTs necessitates opening the electrical panel cover, and, therefore, requires a licensed electrician for the install (in accordance with applicable safety and contracting requirements). The preferred installation of the voltage taps is on three spare, single-pole breakers, but, depending on the specific panel circumstances, other approaches such as tandem breakers, double-tapping, or wire-splicing can be used to integrate the voltage taps. The power requirement of the CLASP meter is <0.03 A and, therefore, will not significantly affect the load ratings of the electrical breaker to which it is attached. In the installation for this technology demonstration, spare breakers were deactivated temporarily and used for the voltage taps, and the entire installation was able to be performed without de-energizing the panel.

To transport the data from the CLASP meter to the cloud-hosted data storage, one can use the LAN ethernet, Wi-Fi, or cellular communications. There is an ethernet jack built into the CLASP meter, and this can be used to connect directly to the building ethernet via an available drop or it can be used to connect to optional cellular or Wi-Fi kits to use those methods of communication. Due to the pilot nature of this technology demonstration, it was desirable to use cellular communication and avoid connecting to the building ethernet. This was primarily due to project timeline considerations, as there was a lengthy cyber review and approval process for connecting a new device to the LAN. The initial cyber review did not flag any concerns with the device and allowed installation for the pilot project with cellular communications.

The installation of CLASP for the Salt Lake City courthouse was comprised of five separate CLASP meters monitoring 96 individual electrical breakers. Four of the CLASP meters were monitoring standard electrical panels, and one was monitoring breakers in a motor control center. The installation took place over 1 ½ days, with a total of ~10 hr for an electrician and ~4 hr of support from a junior/apprentice electrician. There were no significant challenges with the installation, and the majority of the time was spent mounting the meters and running conduit from the meter to the electrical panels. As noted above, this installation used 3G cellular to transport the data from the meter to the cloud, and, therefore, required an additional enclosure for each meter (except on the second floor where two meters shared one communications device) that housed the 3G communications device and antennae. The 3G cellular approach enabled a streamlined pilot project timeline but required additional labor hours during the installation that may not be required when ethernet drops are available for the meters to connect directly into. While no official interviews were conducted during the installation of this CLASP product, the installing electrician noted that the product was "a straightforward install" and that the installation guidance was thorough and useful.

After the installation occurred, a provisioning sheet was emailed to the CLASP provider that documented which sensors were connected to which panel loads. The CLASP provider then provisioned the system and streaming data became available via the web-based user interface or via the API within 24 hr.

The Enertiv technology has been designed and is advertised as a standalone system for data analytics and reporting. However, the technology can be integrated with GSA Link, a system that connects the building management system to a central cloud-based platform using SkySpark. During the accuracy

verification step, NREL pulled data through the CLASP online interface and uploaded it to NREL's SkySpark server for data storage, processing, and analysis. A similar approach is viable to work with the GSA Link system.

b Integration with GSA IT Systems

There are two main integration points for CLASP into the GSA IT systems:

1. Integration to support transport of measured data from the meter to the cloud
2. Integration of cloud-hosted data into enterprise systems or utilization of the analytics user interface.

As noted in Section III.B.a1, this technology demonstration did not test item #1. We elected to utilize a 3G cellular connection for transmission of data from the CLASP to the cloud-hosted data storage. This was due to the expected duration of a full cyber/IT review of the system to allow interconnection with the building network. While the full cyber/IT review was not conducted, an initial review was performed by GSA cyber security personnel, and no security issues were identified during that review.

We were able to test aspects of the second integration point listed above, with a focus on integration of the CLASP data into the GSA Link system that GSA uses as its enterprise-wide building management and FDD platform. One of the primary components of the GSA Link platform is SkyFoundry's SkySpark software. NREL tested the integration of the CLASP data into this platform by establishing a continuous import process from the cloud-hosted storage to an instance of SkySpark running on the NREL network. This import process utilized the RESTful API provided by the CLASP system to write data continuously to established points in the SkySpark instance. This was a relatively straightforward process that required a one-time setup, after which data streamed continuously during the entire period of data collection (~1 yr). We estimate approximately 8–12 hr were required to integrate these systems, with the task executed by an engineer experienced with RESTful APIs and SkySpark. This process effectively tested the integration with the GSA Link platform, while not connecting directly to the system. During discussions with the GSA Link team, we established that the process for actual integration of the data (assuming a larger deployment) would require a firewall exception for the IP address that was serving the API. Given that there are already similar exceptions in place, this integration seems possible given sufficient time for review.

The second aspect of integration with GSA Link that we wanted to assess was the usability of the CLASP data in this context. One of the primary functions provided by the GSA Link platform is FDD; the identification of incorrect operations, including either out-of-hours operations or incorrect operation of certain building systems. To evaluate the ability of the data provided by the CLASP to assist in this function, we assessed the 67 pre-programmed rules that are included in a standard deployment of the GSA Link system to a new building. We looked at whether the CLASP data could support identification of the issues assessed by these 67 rules and found that 28 of the 67 standard rules could be checked using the CLASP data. It was clear that certain rules regarding mechanical operation of the building HVAC (e.g., "AHU Cooling Valve Leaking") would not be able to be assessed with the power data provided by the CLASP, yet evaluation of equipment failure, scheduling issues, or cycling could be evaluated. In addition, the CLASP data could enable the assessment of whole new categories of end uses, such as lighting and plug loads that are typically not integrated into the BAS.

The following general conclusions were reached regarding the ability of CLASP data to enable assessment of the established rule set:

- CLASP data can support scheduling, cycling, and equipment failure rules
- CLASP data may be difficult to use for rules regarding sensor issues, stability of dampers/valves, and simultaneous heating/cooling
- CLASP data provide the ability to monitor lighting/plug loads.

Finally, a sample FDD rule—short-cycling of equipment—was assessed by implementation of the rule into the NREL SkySpark instance. This rule was selected for testing because we had identified short-cycling of the CRAC units during the data center audit discussed in Section III.A.a. After implementation of the rule in the NREL SkySpark system, we evaluated the “sparks” identified by the rule for CRAC 1 during the same week in February, as shown in Figure 13. The periods that would have flagged short-cycling of that piece of equipment are shown in Figure 15. It is worth noting that the traditional GSA Link system would not have been able to capture this faulty operation, as these CRAC units are not on the BAS for this building.

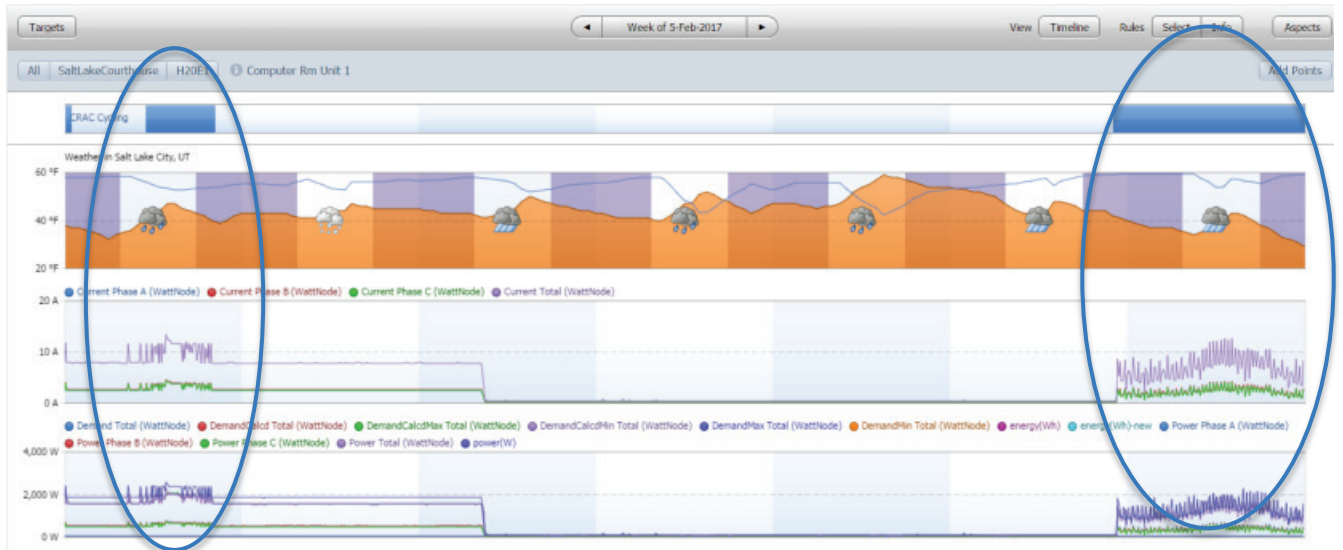

Figure 15: Screen capture of the identified short-cycling fault on CRAC 1, showing potential use of CLASP data in the GSA Link system (screen shot from SkyFoundry’s SkySpark platform as deployed on NREL campus)

We have shown that (1) the system was able to be installed smoothly and efficiently in a variety of panels in a GSA building, (2) the data from the CLASP system can be effectively integrated into the GSA enterprise FDD system GSA Link, and (3) these data can be effectively used to identify faulty operation of equipment or out-of-hours operation of equipment. This meets the qualitative performance objective of the demonstration.

C. COST-EFFECTIVENESS

Objective 5: Value Proposition and Cost-Effectiveness Analysis

This objective is challenging to assess for CLASP technology because the technology provides data that can drive energy savings but does not actually save any energy directly. Additionally—as discussed in

Section I.B—there are various use cases that CLASP can support, each with their own potential revenue streams. Finally, many of these value streams are site specific. For example, the FDD use case may have very different energy and cost savings potential in a building that has recently received retro-commissioning and is running well versus a building that has been drifting out of tune for a number of years and has limited staff to support operations.

While it is difficult to establish general cost-effectiveness of this technology (for the reasons listed above), we provide two approaches to quantifying cost-effectiveness of CLASP in the context of this demonstration deployment at Salt Lake City courthouse. The two approaches consist of:

1. Quantifying cost savings derived from identification and resolution of reprogramming ECM on the CRAC units in the second-floor data center
2. Quantifying cost savings derived from accurate billing of overtime utilities for the second-floor data center.

a Cost-Effectiveness: Derived from ECM Identification

To establish the savings associated with addressing the reprogramming of the CRAC units, we calculated the average reduction in cooling power demand for the second-floor data center based on the regression equations from Figure 14, evaluated at the average annual temperature for Salt Lake City (52.8°F⁸) as this ECM will impact all hours of the year. The average reduction in power consumption is 1.95 kW, which results in an annual kilowatt-hour savings of 17,106 kWh/yr (given that this cooling system operates 8,760 hr/yr). Due to the ECM saving both demand and volumetric charges, the blended electricity rate for the site (\$0.0942/kWh) can be used to calculate cost savings. Annual savings are \$1,611 per year.

The cost of the CLASP required to identify this ECM and perform the M&V of savings was calculated as the capital cost of the three meters used to monitor the second-floor data center and associated dry coolers/pumps, along with installation costs and system-provisioning costs. Annual fees for the CLASP are also included for each of the three meters. All system costs, savings, and associated economic metrics are shown in Table 10.

⁸ <https://www.ncdc.noaa.gov/cdo-web/datatools/normals> . Accessed December 14, 2018.

Table 10: Economic Assessment—ECM Identifications

	Baseline (Before)	CLASP Technology (After)	Difference
Equipment Cost¹	N/A	\$1,956	N/A
Installation²	N/A	\$890	N/A
Total Installed Cost per Meter	N/A	\$949/meter	N/A
Annual Fees	N/A	\$1,260/yr	\$/yr
Annual Energy Consumption	144,209 kWh/yr	127,103 kWh/yr	17,106 kWh/yr
Annual Energy Costs (@ \$0.094 kWh)	\$13,584/yr	\$11,973/yr	\$1,611/yr
Simple Payback		2.5 yrs	
Net Present Value³		\$320	
Savings to Investment Ratio		1.02	

¹Equipment Lifespan is assumed to be 10 years.

²Labor is 2.5 hours per meter @ \$59/hr, additional setup and parts cost is estimated at \$250/meter

³Assuming a 3% discount rate and a 0.15% electricity cost escalation rate.

b Cost-Effectiveness: Derived from Actual Billing of Overtime Utilities

Because the second-floor data center operates 24/7/365, the customer agency that uses this building asset pays overtime utilities. Overtime utilities are paid for any assets that are used outside of the regular occupying hours of GSA facilities, and currently the utilities are paid based on estimates of equipment capacities, runtimes, and other relevant factors. The CLASP installed for the second-floor data center provided actual energy consumption values that could be used to bill the customer agency based on actual consumption instead of the calculated energy consumption.

To establish cost savings from the use of actual measured data in overtime utilities billing, we compared the measured consumption to the calculated consumption shown in Table 11. The measured data were available for 314 days. Thus, these data were scaled up by multiplying by 365/314 to reflect what a full year of consumption would represent. The measured data were also scaled down to reflect the post-ECM operation of the HVAC system; this reflects the improved operation at which the system should be operating. The measured consumption by the CLASP is 66,278 kWh more than the current calculation approach for overtime utilities. If GSA were to use the actuals for billing, this would save them \$6,243/yr on its utility bills because the responsible customer agency would be reimbursing them for the energy spent.

Table 11: Comparison of Calculated Overtime Utilities vs. Measured Consumption for One Year

Device	Overtime Utilities (Calculated) [kWh/yr]	CLASP (Measured) [kWh/yr]
CRAC 1	10,074	17,557
CRAC 2	10,074	16,100
CRAC 3	10,074	8,972
Pump 36	2,190	17,424
Pump 37	2,190	33,285
Dry Cooler 1	14,454	17,909
Dry Cooler 2	14,454	15,857
Total	63,510	127,103

The cost-effectiveness analysis for this scenario is presented in Table 12. It was assumed that the higher-quality CTs would be used for this application because it is a billing application. This results in a slightly higher installed cost for the CLASP, yet the recovered energy costs that GSA would receive far outweighs that added cost, and the system pays for itself in less than 10 months.

Table 12: Economic Assessment—Overtime Utilities Billing Based on Actual Consumption

	Baseline (Before)	CLASP Technology (After)	Difference
Equipment Cost¹	N/A	\$2,415	N/A
Installation²	N/A	\$890	N/A
Total Installed Cost per Meter	N/A	\$1,101/m	N/A
Annual Fees	N/A	\$1,260/yr	N/A
Annual Energy Billed to Tenant	63,510 kWh/yr	127,103 kWh/yr	63,593 kWh/yr
Annual Energy Payments Received (@ \$0.094 kWh)	\$5,982/yr	\$11,973/yr	\$5,990/yr
Simple Payback		0.8 yrs	
Net Present Value³		\$37,463	
Savings-to-Investment Ratio		3.68	

¹Equipment lifespan is assumed to be 10 years.

² Labor is 2.5 hr/m at \$59/hr; additional setup and parts cost is estimated at \$250/m.

³This assumes a 3% discount rate and a 0.15% electricity cost escalation rate.

It should be noted that these savings completely depend on how the original calculations were determined for overtime utilities, and that in some cases this could result in GSA receiving lower payments from the customer agency (if the actuals were lower than had been estimated). Regardless, this approach would result in two benefits for GSA and its customer agencies:

1. Increased accuracy in the overtime utilities billing, leading to improved customer agency relations
2. Incentivization of energy efficiency for the customer agencies using the equipment billed on overtime utilities, seeing as they would see reduced utility costs if they drove toward efficient operation of equipment.

c Summary of Cost-effectiveness Assessment

In both approaches to quantifying cost-effectiveness of the CLASP, we find the installation to be life cycle cost-effective with very short payback periods. We note, however, that a simple payback period may not be the best metric for this technology given the relatively high recurring cost, which is not captured in this metric.

As noted above, assessing cost-effectiveness of the technology is inherently difficult due to the fact that CLASP provides data (and analysis via the user interface) but does not provide direct energy or cost savings. The opportunities identified will vary widely based on the building in which it is installed, and actualization of any savings identified will depend on actions being taken by the building manager or facilities operation staff. For this case study, CLASP was cost-effective based on the actions taken by the building manager during the project, and we established that the technology successfully met its metric of providing actionable insights in a cost-effective manner.

IV. Summary Findings and Conclusions

A. OVERALL TECHNOLOGY ASSESSMENT AT DEMONSTRATION FACILITY

Installation of CLASP technology at the Salt Lake City courthouse successfully met all of the performance objectives laid out in the demonstration plan, with the exception of the high-accuracy expectation of the laboratory testing section, where most of the tests did not achieve a +/-1% accuracy goal.

Three primary goals for studying this technology were established:

1. Enabling evaluation of building energy performance and achieving improvement in building operations, including identification of ECMs and FDD
2. Acquisition of accurate, high-resolution data and using those data as a driver for energy savings associated with occupant behavior change (e.g., tenant incentive programs)
3. Acquisition of accurate, high-resolution data for the purpose of tenant billing.

Success in addressing goal #1 was demonstrated by utilizing CLASP to deliver key insights in an energy audit of the second-floor data center at the Salt Lake City courthouse. Based on audit findings, the building manager reprogrammed the CRAC units, resulting in ~10% savings for the data center HVAC based on observed data for 2 weeks before and after the reprogramming effort. Goal #1 was also met through successful demonstration of integrating CLASP data into the GSA Link software component SkySpark. This capability would enable ongoing FDD on devices monitored by CLASP. This would then enable monitoring of lighting and plug load devices, which adds two significant end uses to the FDD capability provided by GSA Link and would allow additional rule sets based on device power consumption. Demonstration of CLASP data integration expands the opportunities for FDD across the GSA portfolio:

- For buildings with an existing GSA Link deployment, this would enable monitoring of additional end uses.
- For buildings that do not have GSA Link deployed, the GSA SkySpark platform could be used with CLASP data. This would provide an FDD capability for these buildings (albeit with reduced functionality) without full BAS integration and GSA Link deployment.
- This approach would deliver FDD functionality for buildings where a centralized BAS does not exist, thereby enabling FDD for a set of GSA buildings that would not have this capability otherwise.

The energy audit approach for data centers that was piloted in this project also presents a potential model for tenant engagement on overtime utilities and tenant-owned equipment, addressing goals #2 and #3. We have shown that CLASP can provide accurate, high-resolution data—given appropriate

selection of CTs for intended application—as outlined in the performance objectives. Therefore, these data could be utilized for tenant billing on overtime utilities. This opens up a wide variety of tenant engagement opportunities, all premised on the switch from calculated energy costs to billing on actual energy consumed. Tenants could (1) procure a standard data center energy audit that would leverage the exact same data used for the billing and could identify ECMs leading to measurable savings and (2) address identified ECMs, reducing their utility costs and saving energy.

Overall, this technology performed well in this deployment, providing ECM identification ability and tenant engagement and billing capabilities in a cost-effective manner.

B. LESSONS LEARNED AND BEST PRACTICES

The key lessons learned during this demonstration include:

- High-accuracy CTs were required to achieve the level of accuracy needed to meet the performance objective of accurate power and energy data. Specifically, CTs designed to limit phase angle shift to $<0.5^\circ$ were specified in this demonstration. Accuracy results were significantly improved after installing these CTs. High-accuracy CTs are generally in the \$20–\$40 range per CT, whereas the regular CTs are an order of magnitude cheaper. For the three meters required to monitor the data center, the higher-accuracy CTs increased the installed cost by ~23%.
- Access to and utilization of the CLASP data can be achieved either through the native user application provided by the vendor or by API access. API access enables integration of CLASP data into existing analytics platforms, thereby avoiding the need for additional user interfaces that the building manager/operator must become familiar with; enterprise software such as GSA Link can be used as the interface to this new set of data and extended capabilities.
- Identification of the circuits for observation can be a time-intensive process. It is important to have clear goals as to the site’s monitoring objectives prior to deployment.
- It is not always easy/possible to identify clearly which loads are associated with which circuits. This can result from inaccurate panel schedules, obscure naming conventions, or lack of circuit tracing. This is important to consider when trying to isolate monitoring to a specific tenant, space, or set of devices. Circuit tracing can be executed to clearly match all loads to panel circuits, though this may be an expensive process for locations with many, low-load receptacles.
- While the CLASP has a small form factor and integrates smoothly into the electrical panel, it is still necessary to identify wall space in the electrical room for the system and the associated conduit. Caution should be exercised when laying the cabling of the CTs to avoid clutter inside the panel. The enclosure is approximately 7” x 7” x 3.5”, and conduit needs to be run from the enclosure to the existing panel, so proximity to the electrical panel is convenient.
- A registered electrician will be required to install the system in accordance with site safety requirements. Special attention should be given to the installation of the voltage tap, and availability of a spare breaker in the panel will facilitate easier system installation.
- Achieving savings from CLASP depends on utilizing the data it provides (either via improved billing or via identification of operational faults). In either case, it is necessary to have an engaged and motivated building manager or operator that will act on these data.

C. DEPLOYMENT RECOMMENDATIONS

The CLASP system was installed efficiently into an existing building. However, it could have been implemented in a new construction just as easily. The system is flexible and allows single- or three-phase panels, multiple voltage configurations (e.g., 120 V, 240 V, or 480 V), and power levels with matching CT sensors.

If using the wireless or cellular data connections, the bridge requires strong Wi-Fi or cell signals to avoid package drops and missing readings. Heavy concrete construction, metal enclosures, and interference from other wireless sources could reduce signal strength. If the signal is weak, we recommend installing an extender for Wi-Fi and choosing a wireless carrier that provides a strong signal in the case of cell coverage. While connection to the LAN will entail cyber security approval (and associated challenges), this will provide the cleanest delivery of data from the CLASP to their cloud storage database.

To achieve high-accuracy measurements, NREL recommends the use of high-accuracy CTs, such as the Accu-CTs used in this study. This will reduce error associated with phase angle shift and will also deliver high accuracy at current draw well below the rated CT amperage (these typically retain their full accuracy down to 1% of rated current). If possible, it is recommended to size CTs to estimated power levels as opposed to rated breaker values. This may be achieved by metering current with an ammeter to estimate amperage draw and sizing the CT accordingly.

CLASP technology has applicability throughout the GSA portfolio. It will provide the most value where specific devices or end uses can be identified as requiring accurate power data. For example, devices where customer agencies are paying for overtime utilities, customer-agency-owned equipment, and devices with high power consumption are all scenarios where CLASP technology will deliver significant insight and have the potential to drive more significant savings. Payback from identified ECMs or from measured versus calculated energy consumption (billing application) will be more quickly achieved in areas with high utility rates. In addition, loads and devices that are not integrated into the BAS may be worth considering for monitoring via CLASP. This technology provides the capability to apply FDD to those systems where typically they are not monitored on an ongoing basis.

V. Appendix

A. MANUFACTURER CUT SHEET

Technical Specifications

⚙️ Operation		🔌 Power	
Service Type	Single Phase, 3 Phase - 4 Wire (WYE)	Input Voltage (Current)	100–300VAC - (30mA)
Measurement Type	Current (A), Voltage (V), Power Factor, Frequency (Hz), Power (kW, kVA, kVAR)	Frequency	50–60Hz
Measurement Range	0–1,000A, 100–300VAC Line-to-Neutral	Power Consumption	3W
Input Channels	42	⚙️ Mechanical	
Sampling Frequency	500kHz	Operating Temperature	32°–122°F (0°–50°C)
Update Rate	1s	Storage Temperature	-4°–158°F (-20°–70°C)
Measurement Accuracy	±1% at full range	Humidity	< 85% RH, non-condensing
Storage	1 month of offline data storage	Enclosure	IP66 (NEMA Type: 4X), Polycarbonate, Transparent Cover
Indicators	1. Blue LED: Collecting Data 2. Red LED: Power	Weight	2lbs (907.2g)
🌐 Network Communications		Dimensions	7.09" x 7.17" x 3.54" (180mm x 182mm x 90mm)
Type	Ethernet		
Port	RJ-45		
Communication Rate	10/100Mbps		



Figure 16: EnertivTwo cut sheet